

# User's Guide

anyfeed™ SXM100/140/200

anyfeed™ SX160/240/340

Revision E, Edit 3

Document name: UG anyfeed SX SXM eng.docx



# Table of Contents

1	Overview.....	4
1.1	Introduction .....	4
1.2	Product Description .....	4
1.3	Warnings, Cautions, and Notes in Manual .....	5
1.4	Declaration by the manufacturer on integration and conformity .....	6
1.5	Intended Use of anyfeed SX and SXM Feeder .....	6
2	Installation.....	8
2.1	Unpacking and Inspecting the flexfactory Equipment.....	8
	Before Unpacking.....	8
	Upon Unpacking.....	8
2.2	Repacking for Relocation .....	8
	Unpacking .....	9
2.3	Mechanical Installation.....	9
	Preparing a Mounting Location .....	9
	Moving the anyfeed to the Mounting Location.....	13
2.4	Installing the Pneumatic Line.....	14
2.5	Electrical Interface Panel .....	15
	Interface Panel.....	15
	Electrical Connectors on Interface Panel.....	15
2.6	Installing Cables and Power .....	16
	RS232 Cable Installation .....	17
	Connecting the Servo Power Cable .....	18
2.7	EMC protection - Earthing guideline.....	19
2.8	Measures to comply with noise emission limits .....	19
3	Using the anyfeed with Serial Communication .....	20
3.1	Introduction .....	20
3.2	Program Flow .....	20
3.3	Serial Communications .....	21
	Setting the Serial Port Communication Parameters.....	21
3.4	Serial Command Codes .....	21
	Sending Commands to the anyfeed.....	21
	anyfeed Responses .....	26
	Serial Dialog Examples .....	29
	Initializing the anyfeed.....	29
	Feeding Parts Forward.....	29

Changing the Feed Forward Repetitions .....	30
Changing the Flip speed/intensity .....	30
anyfeed not Initialized .....	30
Servo Problem on Flip Drive .....	31
Servo Problem on Disp Drive .....	31
Unknown Command .....	31
4. Maintenance – anyfeed SXM100, SXM140 and SXM200.....	32
4.1 Introduction .....	32
4.2 Periodic Maintenance .....	32
4.3 Removing and Installing the Feed Surface.....	33
5. Maintenance – anyfeed SX160, SX240 und SX340.....	34
5.1 Introduction .....	34
5.2 Periodic Maintenance .....	34
5.3 Removing and Installing the Feed Surface.....	35
5.4 Retainer Speed Settings on anyfeed SX160/SX240.....	36
5.5 Restraint Setting on anyfeed SX340.....	38
6. Backlight .....	40
6.1 Introduction .....	40
6.2 Preparing the Installation .....	40
6.3 Installing the LED Controller .....	42
6.4 Installing the Backlight.....	44
7. Technical Specifications.....	45
7.1 Dimensions.....	46
7.2 Specifications .....	51

# 1 Overview

## 1.1 Introduction

This manual describes the key points for getting your anyfeed operational. Before getting started, make sure you have all the components necessary to set up your anyfeed. In addition to the anyfeed (shown in Figure 1-1 below), it is assumed that you have the appropriately configured -controlled robot with vision guidance. (See Section 1.3 and Section 2.1 for details.)

## 1.2 Product Description

Your anyfeed provides flexible parts feeding without the limitations of a hard-tooled feed system (such as a bowl-feeder or tray-feeding system).

The anyfeed is designed for feeding a wide variety of parts with rapid change-over times.

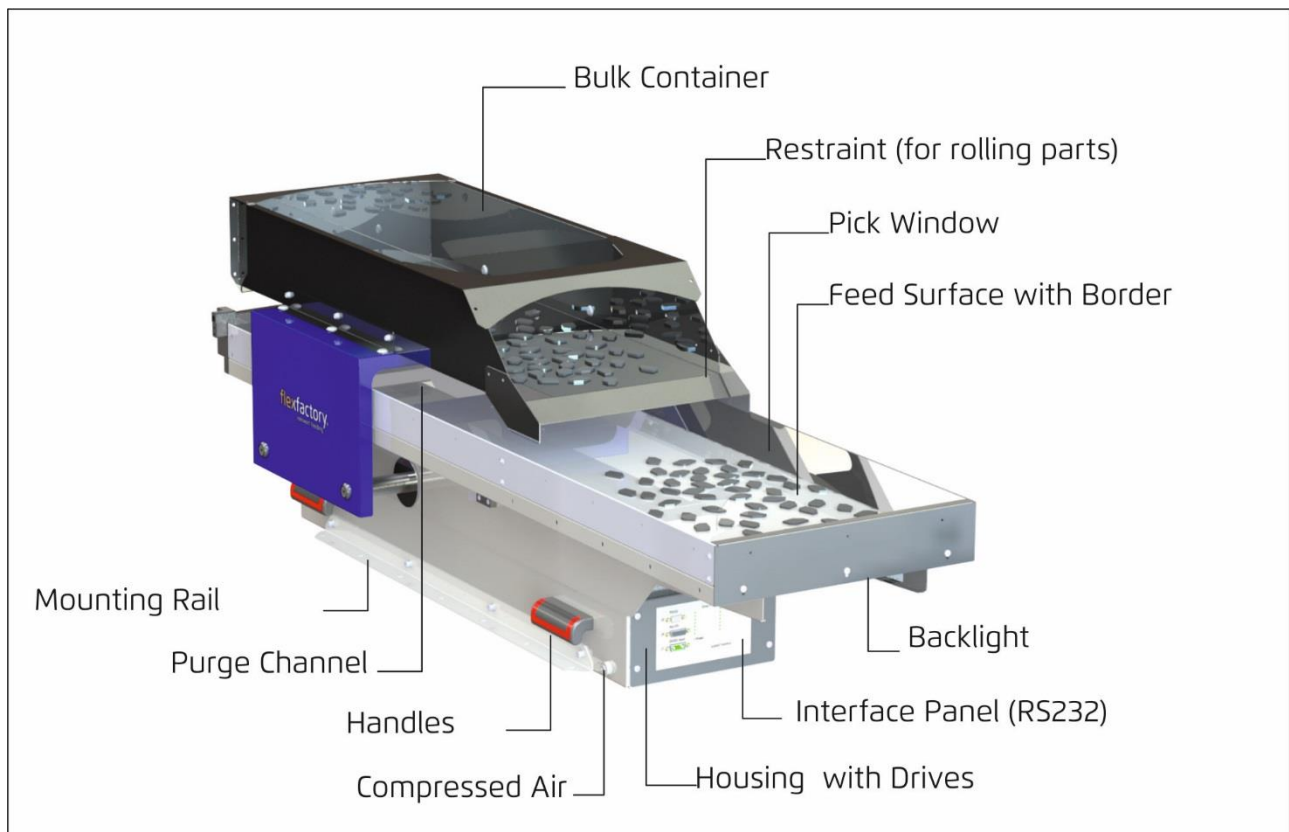

Figure 1-1: anyfeed parts, model SX340 shown

There are different anyfeed models available:

- anyfeed SXM100
- anyfeed SXM140
- anyfeed SXM200
- anyfeed SX160
- anyfeed SX240
- anyfeed SX340

**NOTE:** In most aspects, the feeders are similar enough that they will be covered together. In areas where there are significant differences, information is given for the most models or presented in single chapters such as “Maintenance”.

Your anyfeed package includes:

- anyfeed
- 24-VDC Power Cable, 5 m
- RS232-Cable, 4,5 m

### 1.3 Warnings, Cautions, and Notes in Manual

There are five levels of special alert notation used in this manual.

In descending order of importance, they are:



**DANGER:** This indicates an imminently hazardous electrical situation which, if not avoided, will result in death or serious injury.



**DANGER:** This indicates an imminently hazardous situation which, if not avoided, will result in death or serious injury.



**WARNING:** This indicates a potentially hazardous electrical situation which, if not avoided, could result in injury or major damage to the equipment.



**WARNING:** This indicates a potentially hazardous situation which, if not avoided, could result in injury or major damage to the equipment.



**CAUTION:** This indicates a situation which, if not avoided, could result in damage to the equipment.

**Note:** Notes provide supplementary information, emphasize a point or procedure, or give a tip for easier operation.

## 1.4 Declaration by the manufacturer on integration and conformity

The documents for the anyfeed will be handed over separately upon request.

## 1.5 Intended Use of anyfeed SX and SXM Feeder

The feeders of the anyfeed™ SX/SXM series are intended for the use in combination with an industrial robot and vision system, with the purpose to store and singulate bulk parts for easy pickup by a robot. The working principal is illustrated in the diagram below.

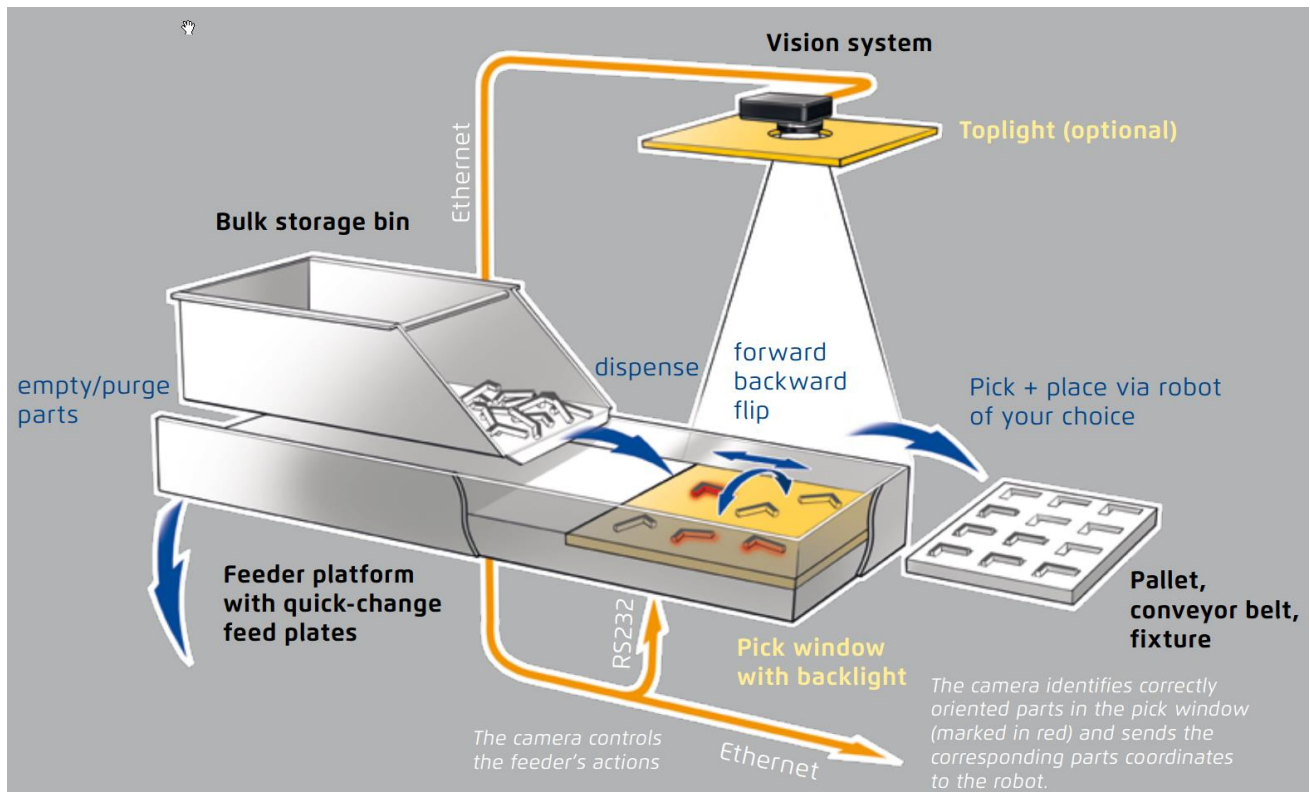

Figure 1-2: Working principle anyfeed/robot/vision

The feeders of the anyfeed™ SX/SXM series are exclusively intended for use in the following industrial areas and applications, for the purpose to store and singulate parts for later pickup by a robot:

- Small part assembly, material handling, and quality control
- Part packaging applications
- Part counting applications
- Loading of process machines

The feeders of the anyfeed™ SX/SXM series must be operated at any time under the following **ambient conditions**: 5-40 degrees Celsius, humidity 5-90% (no condensation).

All operating personnel must be instructed and trained to safely operate the complete system, comprised at minimum of feeder/robot/gripper/vision.

All operating personnel must have read and fully understood all safety relevant aspects of this user manual/guide.

The feeders of the anyfeed™ SX/SXM series are **NOT** to be used:

- for handling food products
- in explosive environments
- for wet, oily and visibly contaminated parts
- for applications in radioactive environments resp. handling radioactive parts
- in outdoors applications

The feeders of the anyfeed™ SX/SXM series are considered incomplete machines in accordance with the European Machinery Directive 2006/42/EU.

**Other applications not mentioned in this documentation, require approval by flexfactory ag in writing.**

## 2 Installation

### 2.1 Unpacking and Inspecting the flexfactory Equipment

#### Before Unpacking

The anyfeed SX series is shipped in a carton that is banded onto a wooden pallet.

Carefully inspect the carton for evidence of damage during transit. Pay special attention to any tilt and shock indication labels on the exteriors of the carton. If any damage is indicated, request that the carrier's agent be present at the time the carton is unpacked.

#### Upon Unpacking

Before signing the carrier's delivery sheet, please compare the actual items received (not just the packing slip) with your equipment purchase order and verify that all items are present and that the shipment is correct and free of visible damage.

- If the items received do not match the packing slip, or are damaged, do not sign the receipt. Contact flexfactory as soon as possible.
- If the items received do not match your order, please contact flexfactory immediately.

Inspect each item for external damage as it is removed from its carton. If any damage is evident, contact flexfactory.

Retain all cartons and packaging materials. These items may be necessary to settle claims or, at a later date, to relocate equipment.

### 2.2 Repacking for Relocation

If the anyfeed or other equipment needs to be relocated, reverse the steps in the installation procedures that follow. Reuse all original packing containers and materials and follow all safety notes used for installation. Improper packaging for shipment will void your warranty. Specify this to the carrier if the anyfeed is to be shipped.

## Unpacking

To unpack the anyfeed:

1. Use a forklift or hand truck to move the shipping carton with pallet to the installation area.
2. Cut the banding with a utility knife or scissors.
3. Raise the shipping carton cover straight up until it clears the contents, and then remove it.
4. Detach the anyfeed from the shipping pallet by using a 4 mm Allen key and 10 mm wrench or socket to remove the four (4) screws from the mounting rails of the anyfeed, as shown in the following figure.



Figure-2-1: Shipping Screws on Mounting Rail

## 2.3 Mechanical Installation

### Preparing a Mounting Location



**WARNING:** The anyfeed must be bolted or clamped down to the base plate at any time it is in operation. Due to its working principle the anyfeed may “walk off” the base plate during operation if it is not properly secured to the base plate.



**WARNING:** Do not connect the anyfeed to electrical power or compressed air before it is securely bolted or clamped down to the base plate.

Before the anyfeed can be used, it must be securely mounted in a prepared location within the robot’s work cell.

Prepare the mounting hole pattern as shown in the relating figure. Locate the mounting hole pattern on the base plate so that the minimum base plate contact of each anyfeed's base housing rests on the base plate, as shown in the following figures.

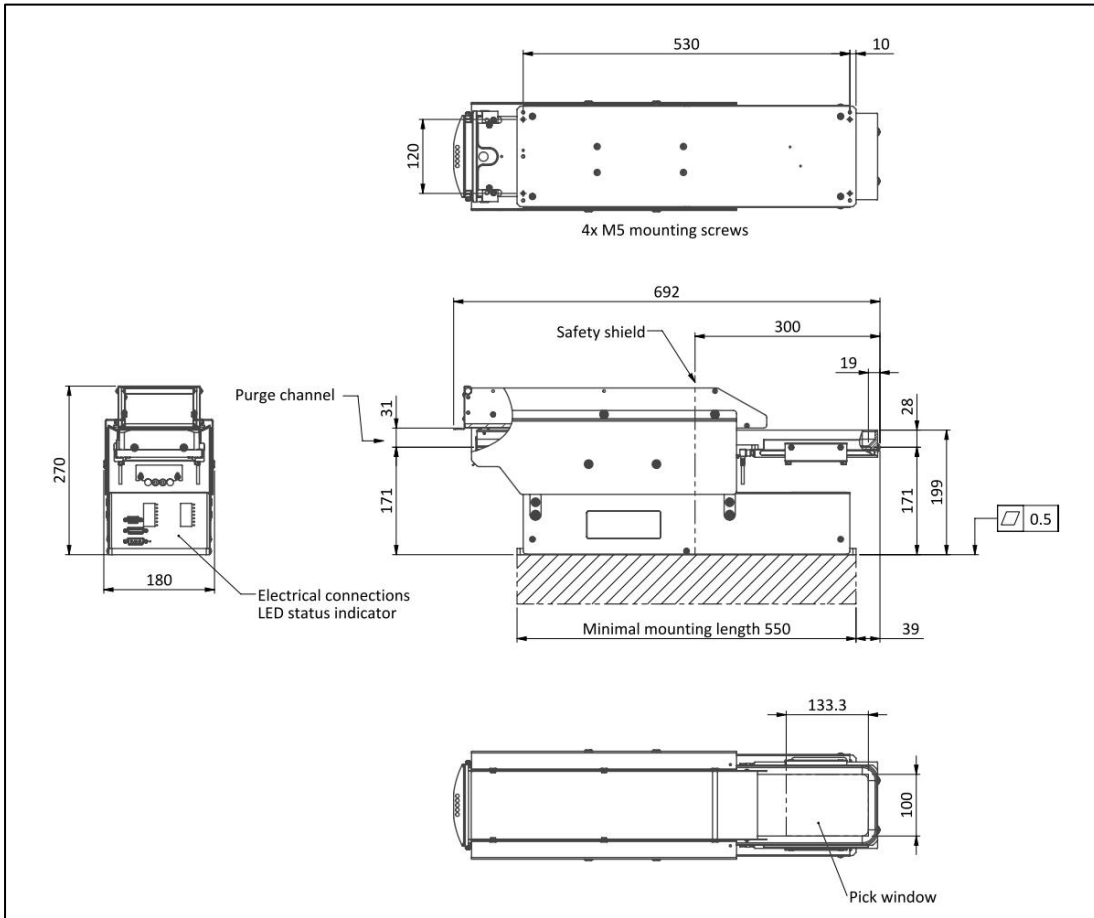

Figure 2-2: anyfeed SXM100

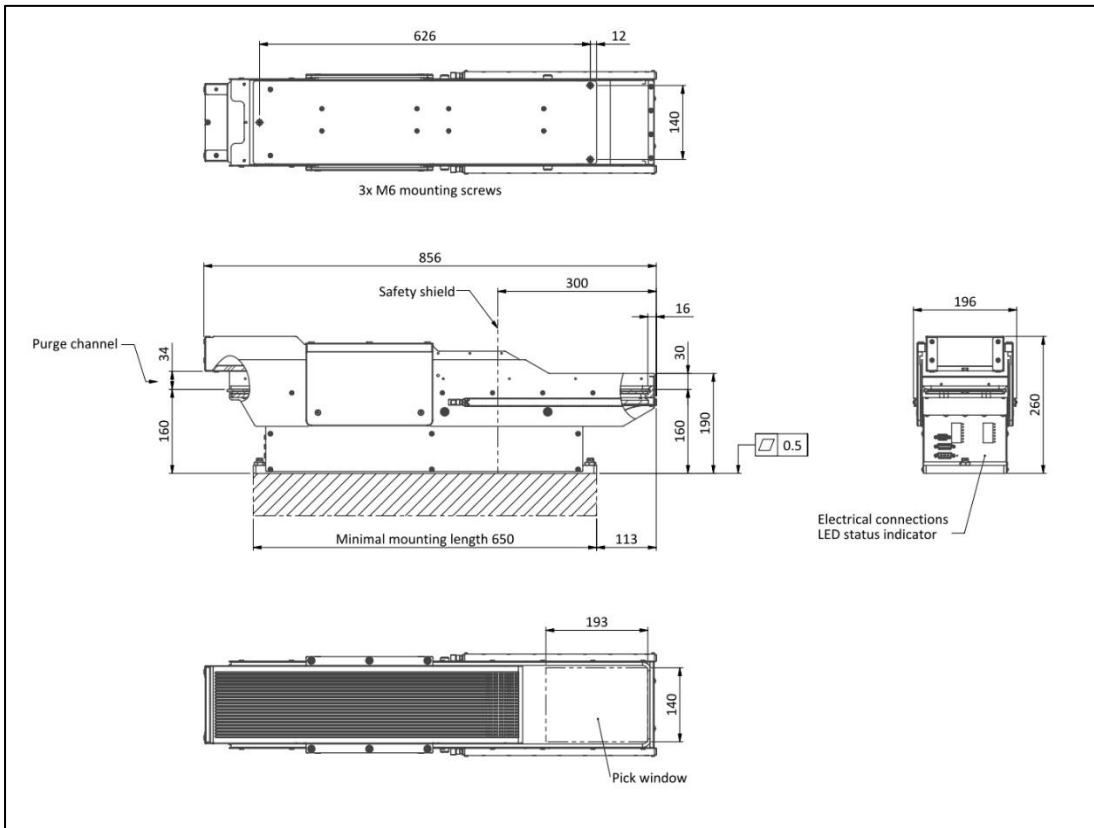

Figure 2-3: anyfeed SXM140

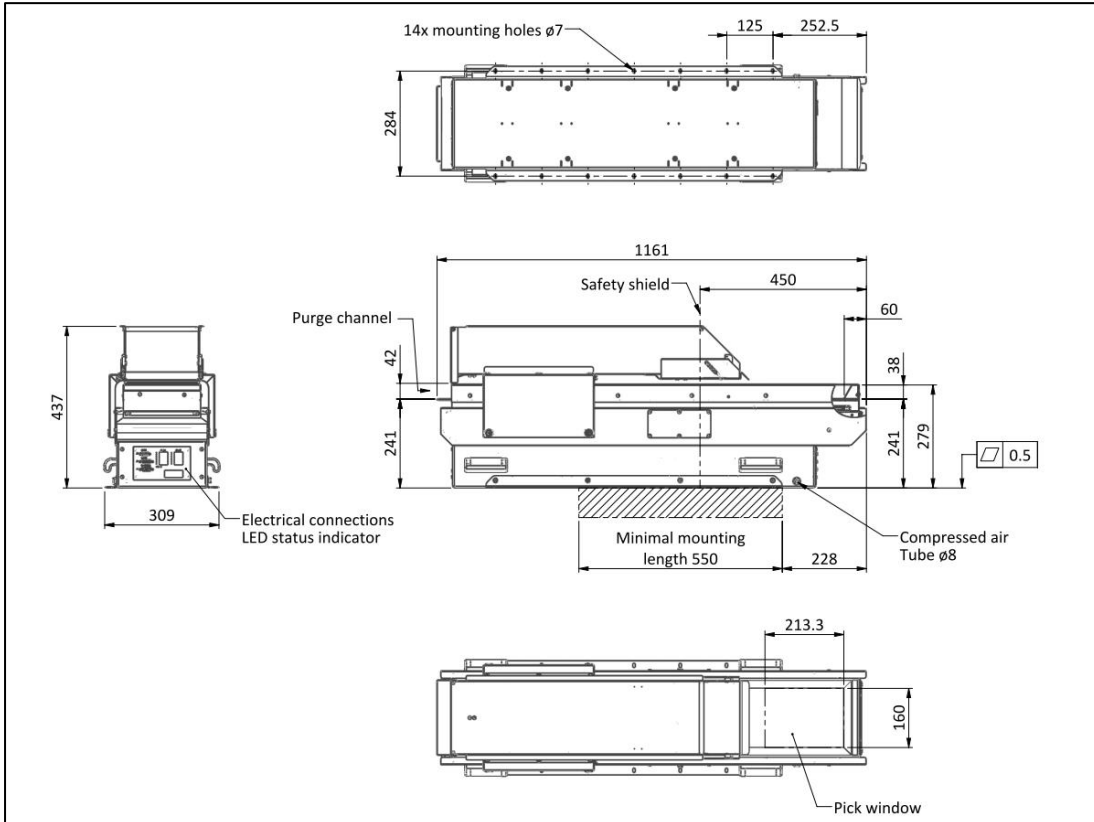

Figure 2-4: anyfeed SX160

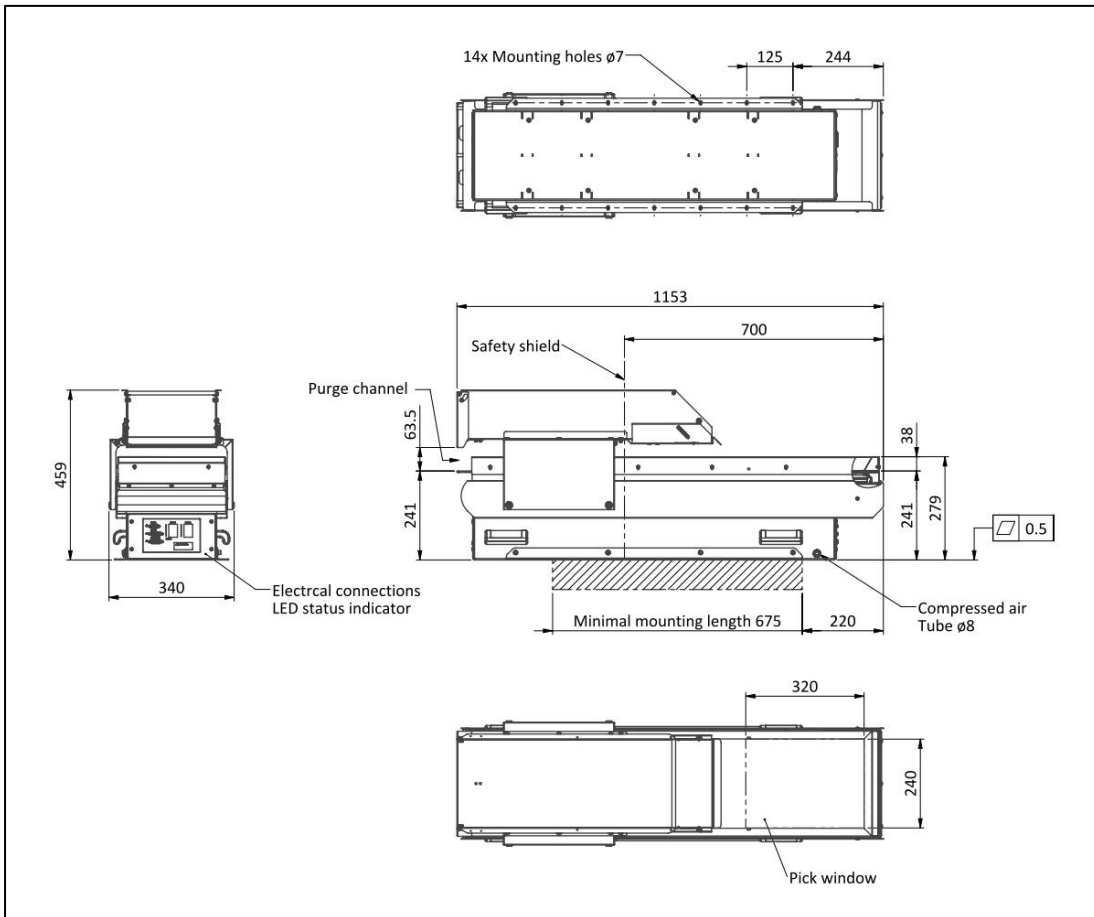

Figure 2-5: anyfeed SX240

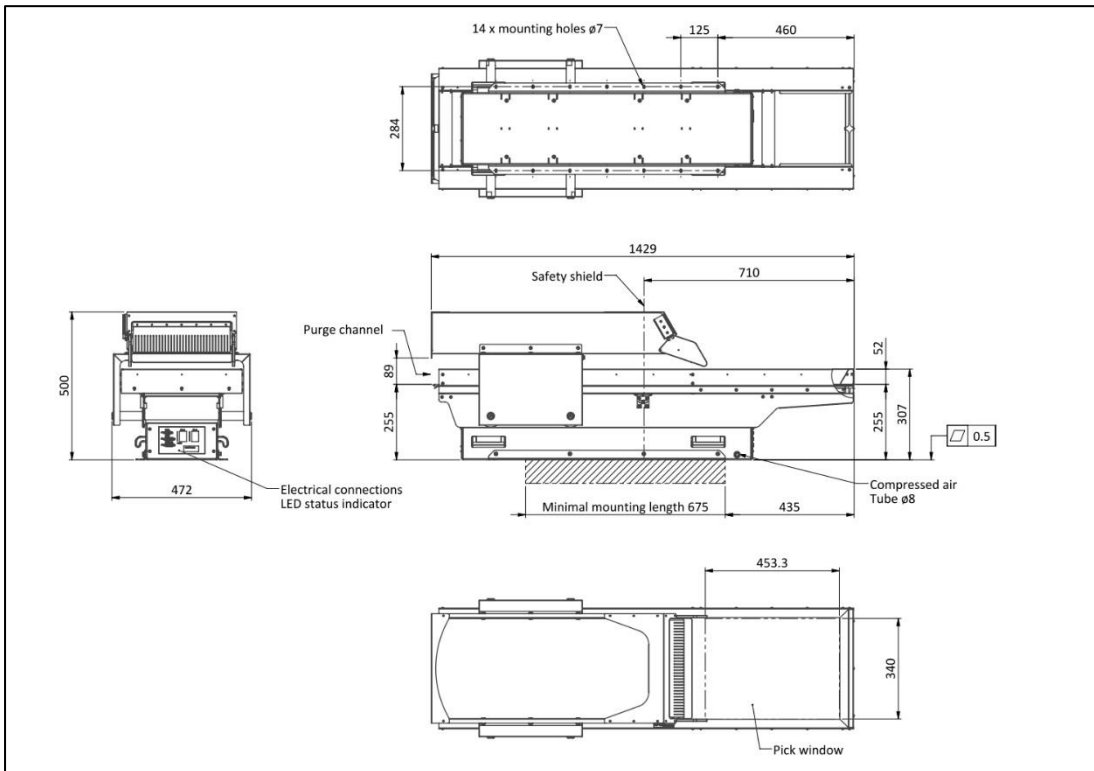

Figure 2-6: anyfeed SX340

## Moving the anyfeed to the Mounting Location



**WARNING:** Two people must lift and move the anyfeed of the SX series to the prepared location. Lift the anyfeed only by holding it at the base housing at the handles. The anyfeed models SX160, SX240 and SX340 provide these handles.

1. Find a co-worker to help you move the anyfeed.
2. Lift the anyfeed by the handles (so far existing) shown in the following figures.



Figure 2-6: Handles

3. Move the anyfeed to the prepared mounting location.
4. Bolt the anyfeed to the mounting location by inserting at least four (4) M6 x 16 mm Allen screws with washers and lock washers through the holes in the feeder's mounting rails (use at least two screws in each mounting rail).

## 2.4 Installing the Pneumatic Line

This section describes the installation procedure of the pneumatic line for the anyfeed SXM140 (8 liter bulk container), SXM200, SX160, SX240 and SX340.

The anyfeed models SXM100 and SXM140 (4 liter bulk container) do not require a pneumatic connection.

1. Locate the pneumatic connector below the side handle on the anyfeed.



Figure 2-7: Pneumatic Connector Location

2. Prepare an 8 mm OD air line.
3. Attach the air line to the pneumatic connector (see following figure). Do not overtighten the connection.



Figure 2-8: Air Line Attached to Pneumatic Connector

## 2.5 Electrical Interface Panel

### Interface Panel

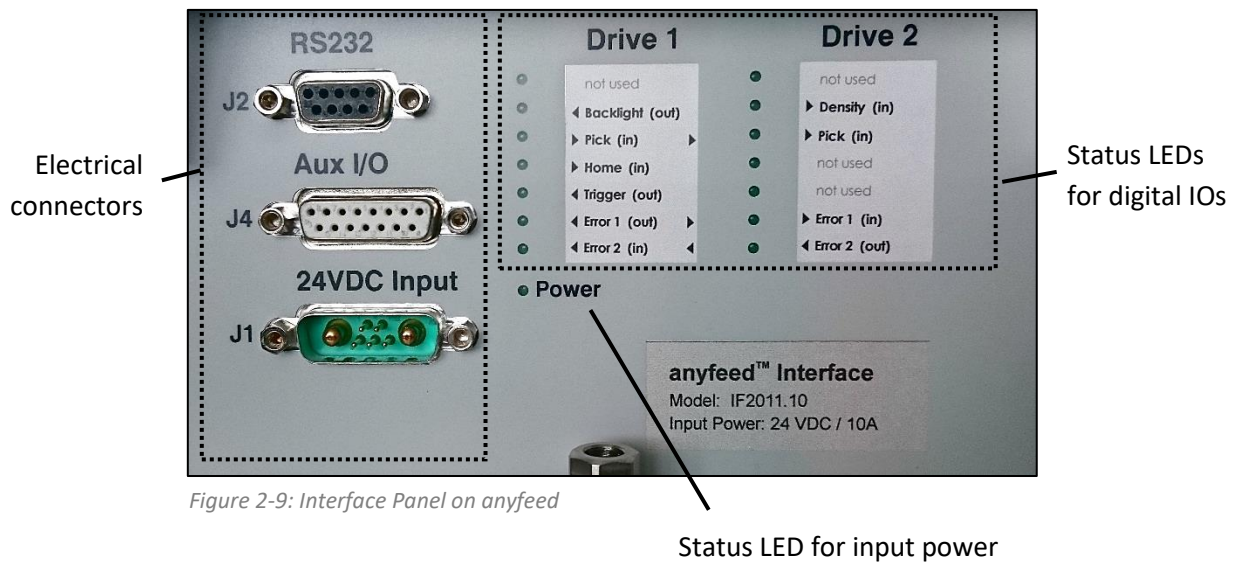

Figure 2-9: Interface Panel on anyfeed

### Electrical Connectors on Interface Panel

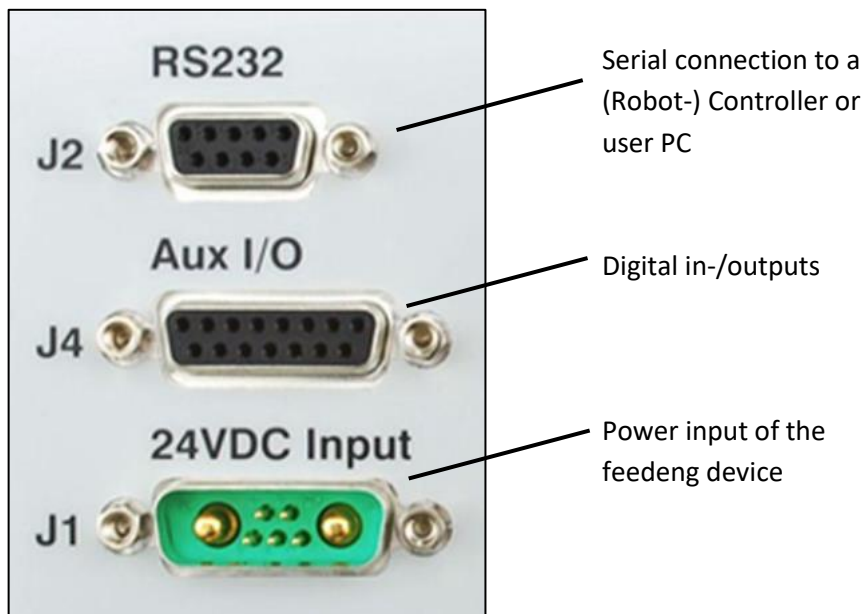

Figure 2-10: Electrical Connectors on Interface Panel

Table 2-1: Electrical connector pinout

Description	Function	Type	Pin- #	Pinout	Cable
J1	Power input for control logic and servo motors	D-Sub-M 2 + 5 male	A1	24 VDC	No. 1 (red)
			A2	GROUND	No. 2 (blue)
J2	RS232	D-Sub 9, female	2	RX	D-Sub 9, female
			3	TX	
			5	GROUND	
J4	Aux I/O (used for the Flexfactory Vision-system with feedWare CX)	D-Sub 15, female	1	Trigger out	User-supplied
			4	GROUND	
			5	GROUND	
			6	24 V out	
			7	24 V out	
			8	Pick in	
			9	Flash in	
			14	Error Drive 1	
			15	Error Drive 2	

## 2.6 Installing Cables and Power

This section describes the electrical installation procedure for the anyfeed.

The anyfeed requires the following cable connections:

- The servo motor power cable (supplied)
- The RS232 serial communications cable (supplied)

**NOTE:** The anyfeed is equipped with a fuse to protect the internal components.

The 24 VDC input line is protected with a 20 Amp fuse. This fuse can be replaced in the field.

If you suspect a problem with the fuse, contact flexfactory Customer Service.

## RS232 Cable Installation

An RS232 cable is supplied with the anyfeed (see following figure).



Figure 2-11: Serial Connections Cable

Connect the male end of the cable to the RS232 (J2) port on the anyfeed (see following figure).



Figure 2-12: J2 RS232 Connections Cable

Connect the female end of the cable to the serial port on the robot controller or PC. Make sure that the cable on the anyfeed port is secured with the two screw locks.

## Connecting the Servo Power Cable

1. Locate the servo motor power cable with connector that was supplied with the anyfeed (see following figure).



Figure 2-13: Servo Power Cable

2. Connect the wire end of the cable to the user-supplied 24 VDC / 10 A regulated power supply:

**Blue** marked wire to 0V/GND of the power supply

**Red** marked wire to +24V of the power supply

3. Connect the **Shield-bracket** (attached to the cable-shield) highly conductive to machine Earth (PE "protective earth"). Use an M4-screw to firmly mount the Shield-bracket to PE in your electrical cabinet.



Figure 2-14: Shield-bracket

4. Attach the connector end of the cable to the Motor Power 24 VDC In (J1) connector on the front of the anyfeed (see following figure).



Figure 2-15: J1 – 24VDC In Connector

## 2.7 EMC protection - Earthing guideline

To discharge electrical interference it is important that the feeding device and connecting cables as well as the power supply and the controlling device are connected highly conductive to the machines Earth (PE "protective earth").



**CAUTION:** Failure to comply with these directions can result in malfunction or damage of the equipment.

The following drawing illustrates the necessary earthing connections schematically:

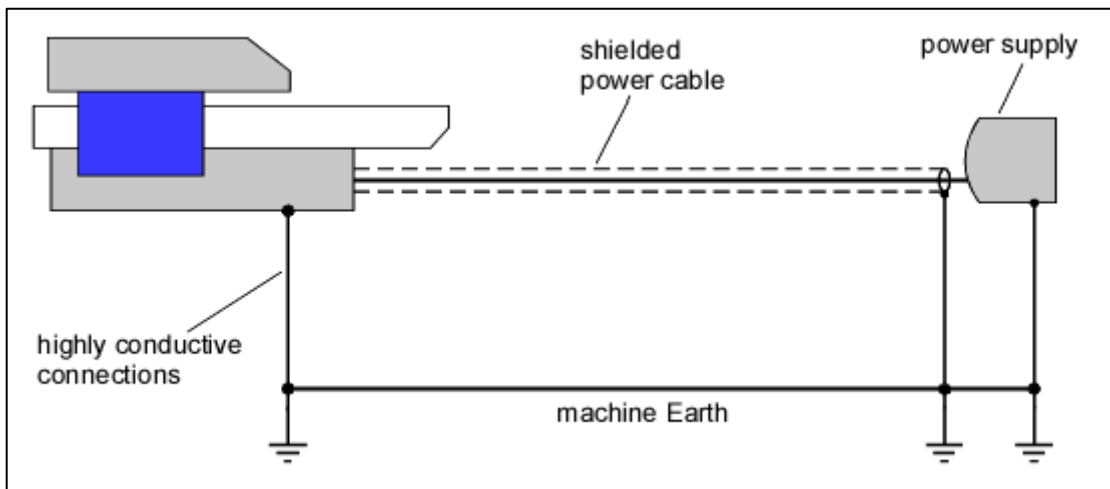

Figure 2-16: Earthing diagram

## 2.8 Measures to comply with noise emission limits

The noise emission of an anyfeed feeding device, without parts, is below 65dBA. Depending on the feed-surface being used as well as the material and weight of the fed parts, in factory operation the noise emission can be up to 85dBA or higher. According to the specific application and installation of the anyfeed-device in a machine or plant, the builder/operator of the overall system must take appropriate measures to comply with noise emission limits for a production plant of typically <75dBA and arrange corresponding safety precautions.



**WARNING:** Failure to follow these instructions can result in health problems. Wearing ear protection and displaying warning signs is recommended.

## 3 Using the anyfeed with Serial Communication

### 3.1 Introduction

This chapter describes the requirements for using the anyfeed with a robot/vision system and serial communications.

### 3.2 Program Flow

The steps below briefly describe a simple program flow for using the anyfeed in the work cell:

1. Initialize the anyfeed
2. Send „dispense“ command to the anyfeed to bring parts from the bulk container onto the feed-surface (pick-area).
3. Acquire a vision image and locate „usable“ parts.
  - a. If usable parts are found proceed with step 4.
  - b. If no usable parts are found go to step 6.
4. Command robot to pick one or more usable parts and place it to the desired destination.
5. Acquire a new vision image as soon as the robot is outside the cameras field of view.  
Go to step 3.
6. If no part is found or the last usable part has been picked up from the feeder, send a feeding-command to reallocate the parts.  
(Which command is executed depends on the situation of parts on the feeder.)
7. After a defined settling time, so that the parts have stabilized, acquire a new vision image and locate usable parts.
  - a. If usable parts are found, loop back to step 4.
  - b. If no usable parts are found, and feed area is not empty, repeat step 6.
  - c. If no usable parts are found, and feed area is empty, go to step 2.

### 3.3 Serial Communications

This section describes how to set up serial communications with the anyfeed.

#### Setting the Serial Port Communication Parameters

In order to communicate properly with the anyfeed, you must configure the serial port of your control device as follows:

Table 3-1: Serial Port Settings

Item	Setting
Baud rate	9600
Data bits	8
Stop bit	1
Parity	none
Flow control	none
In addition to the above: - Disable local echo - Termination character is <b>CR</b> =ASCII code 13 (Dec). IMPORTANT: Do <b>not</b> append LF (line feed)! - For better display append „line feed“ to received strings.	

**Note:** The anyfeed will not receive or send any serial data if the baud rate is not set correctly

### 3.4 Serial Command Codes

The following sections describe:

- The serial commands that can be sent to the anyfeed
- How the anyfeed responds to received commands
- Sample serial communications dialogs

#### Sending Commands to the anyfeed

Table 3-3 provides a list of all available anyfeed serial commands.

With each command there is a maximum of two associated parameters which influence that command. Note that some commands do not need any parameters.

During startup, the anyfeed firmware assigns default values to all parameters.

For example, if you send the anyfeed a “feed forward” command without first changing any of its parameters, the anyfeed control system will apply the default parameters (see Table 3-4 for details).

Table 3-2: Description of Symbols used in Tables

Symbol	Description
<cr>	Carriage return, ASCII code 13 (decimal)
<i>speed</i>	Integer in the range 0... 10
<i>turns</i>	Integer in the range 1 ... 10, except for purge (range is 1 ... 127)
_	Explicit space (not an underscore)
Note that all text in the Syntax column is case sensitive.	

See Table 3-7 for a list of standard responses.

Table 3-3: anyfeed Serial Commands part 1

Command	Description	Syntax	Explanation	Response
Feed Forward [ffwd]	Feed parts forward	x=1<cr>	Executes a feed forward	Standard response
Feed Backward [fbwd]	Feed parts backward	x=2<cr>	Executes a feed backward	Standard response
Feed + Flip Forward [flipfwd]	Flip parts forward	x=3<cr>	Executes a flip forward	Standard response
Feed + Flip Backward [flipbwd]	Flip parts backward	x=4<cr>	Executes a flip backward	Standard response
Flip [flip]	Flip parts without moving forward or backward	x=5<cr>	Executes a flip	Standard response
Dispense [dispense]	Move parts from the bulk container onto the feed surface	x=6<cr>	Executes a dispense	Standard response
Purge [purge]	Feed parts out backwards, purge gate must be opened manually	x=7<cr>	Executes a purge	Standard response
Initialize [init]	Move the anyfeed into its home position and clear all possible errors; Required after power-up before any motion command can be executed	x=16<cr>	Initializes the anyfeed	Standard response

Table 3-3: anyfeed Serial Commands part 2

Command	Description	Syntax	Explanation	Response
Stop [stop]	Stops the current motion and moves the anyfeed to home position	x=15<cr>	Aborts currently running feeder-motion, if such is executing	Standard response
Startup feed firmware	Start anyfeed firmware (also stops active motions)	S_RUN<cr>	Restarts anyfeed firmware	m10<cr> m20<cr> (to indicate the anyfeed is ready)
Reset error	Reset error status and moves anyfeed to home position	x=30<cr>	Resets error status	Standard response
Restart firmware	Restart anyfeed firmware; resets all parameters to default values	x=31<cr>	Restarts anyfeed firmware and resets defaults	Standard response

Table 3-4: Setting Parameters – Number of Repetitions part 1

Command	Description	Syntax	Explanation	Response
<b>Setting the Number of Repetitions</b>				
Set Feed forward repetitions	Set number of repetitions for feed forward	ab[1]=turns <cr>	Sets repetitions	No response
Set Feed backward repetitions	Set number of repetitions for feed backward	ab[2]=turns <cr>	Sets repetitions	No response
Set Feed + Flip forward repetitions	Set number of repetitions for feed flip forward	ab[3]=turns <cr>	Sets repetitions	No response
Set Feed + Flip backward repetitions	Set number of repetitions for feed flip backward	ab[4]=turns <cr>	Sets repetitions	No response
Set Flip repetitions	Set number of repetitions for flip	ab[5]=turns <cr>	Sets repetitions	No response

Table 3-4: Setting Parameters– Number of Repetitions part 2

Command	Description	Syntax	Explanation	Response
Set Dispense repetitions	Set number of repetitions for dispense	ab[6]=turns <cr>	Sets repetitions	No response
Set Purge repetitions	Set number of repetitions for purge	ab[7]=turns <cr>	Sets repetitions	No response

Table 3-5: Setting Parameters– Speed

Command	Description	Syntax	Explanation	Response
<b>Setting the Speed of Operation</b>				
Set Feed forward speed	Set speed of feed forward operation	ab[17]=speed_x=17<cr>	Sets speed	Standard response
Set Feed backward speed	Set speed of feed backward operation	ab[18]=speed_x=18<cr>	Sets speed	Standard response
Set Feed + Flip forward speed	Set speed of feed flip forward operation	ab[19]=speed_x=19<cr>	Sets speed	Standard response
Set Feed + Flip backward speed	Set speed of feed flip backward operation	ab[20]=speed_x=20<cr>	Sets speed	Standard response
Set Flip speed	Set speed of feed flip backward operation	ab[21]=speed_x=21<cr>	Sets speed	Standard response
Set Dispense speed	Set speed of dispense operation	ab[22]=speed_x=22<cr>	Sets speed	Standard response
Set Purge speed	Set speed of purge operation	ab[23]=speed_x=23<cr>	Sets speed	Standard response

Table 3-6: Setting Parameters– Other Settings

Command	Description	Syntax	Explanation	Response
<b>Other Settings</b>				
Vision trigger interval	Sets the vision trigger interval in multiples of 50ms	ab[25]=value _ x=25<cr>	Range for value is 10 to 100 (500...5000ms) Default is 2000ms (value=40)	Standard response
Vision trigger delay	Sets the vision trigger delay in multiples of 20ms. The trigger delay starts after an anyfeed action has completed.	ab[26]=value _ x=26<cr>	Range for value is 1 to 100 Default is 200ms (value=10)	Standard response
Set digital output	Sets the state of the anyfeed's internal digital outputs. It is not recommended to set these during normal operation. Only used for debugging purposes	ab[27]=mode _ x=27<cr>	Mode: 0: Engage the dispense clutch (SX-series) 1: Engage the flip clutch (SX-series only) 2: Turn backlight OFF 3: Turn backlight ON 4: Close retainer gate 5: Open retainer gate	Standard response

## anyfeed Responses

After receiving a command, the anyfeed will respond with specific characters to indicate the status of each motor in the mechanism.

### **Motor 1:**

The “flip” drive, located to the front of the anyfeed, under the feed surface.

### **Motor 2:**

The “dispense” drive, located to the rear of the anyfeed, under the bulk container.

## Responses

### ***mix***

Where:

$m$  = "m" stands for "motor" and is not variable

$i$  = the drive number (1 or 2) that is reporting

$x$  = the status of the drive (number from 0 to 9)

The following pages describe the actual responses from the anyfeed. Please note that before any answer always the echo of the sent command is returned. This is not mentioned each time in the following descriptions.

## Standard Responses

During normal operation, the responses you should expect to see from the anyfeed are as follows.

Table 3-7: Standard Responses

Response	Meaning
m11<cr>	Motor 1 understood command and is busy
m21<cr>	Motor 2 understood command and is busy
m10<cr>	Motor 1 completed action successfully and is OK
m20<cr>	Motor 2 completed action successfully and is OK
<p><b>NOTE 1:</b> Motors 1 and 2 may report back in different orders meaning sometimes motor 1 will report back first and sometimes motor 2 will report back first.</p> <p><b>NOTE 2:</b> Because the two motors perform different motions during the same operation, there will be variable delays between the responses.</p>	

Table 3-8: anyfeed Responses part 1

Response	Meaning	Details
m10	Motor 1 completed action successfully	
m11	Motor 1 received command and is busy	
m12	Invalid command	Command number or command syntax incorrect
m13	Motor 1 servo error	Possibly overloaded. Check for obstructions or hardware problems. Error must be reset before operation can continue.
m16	Motor 1 not initialized	anyfeed must be initialized before motion commands can be executed
m17	Motor 1 reports error state on motor 2.	Motor 1 has received error state from motor 2. Error must be reset before operation can continue.
m19	Motor 1 encoder error	No reading from encoder on motor 1. Power-cycle the feeder and try to initialize. If the problem persists, the motor needs to be replaced.
m20	Motor 2 completed action successfully	
m21	Motor 2 received command and is busy	
m22	Invalid command	Command number or command syntax incorrect

Table 3-8: anyfeed Responses part 2

Response	Meaning	Details
m23	Motor 2 servo error	Possibly overloaded. Check for obstructions or hardware problems. Error must be reset before operation can continue.
m26	Motor 2 not initialized	anyfeed must be initialized before motion commands can be executed.
m27	Motor 2 reports error state on motor 1	Motor 2 has received error state from motor 1. Error must be reset before operation can continue.
m28	Timeout – no sync-signal received	The sync-signal was not received from Motor 1. Therefore, Motor 2 cannot start its action. Error must be reset before operation can continue
m29	Motor 2 encoder error	No reading from encoder on motor 2. Power-cycle the feeder and try to initialize. If the problem persists, the motor needs to be replaced.

## Serial Dialog Examples

This section provides some examples of serial communication streams for basic anyfeed operations.

### Initializing the anyfeed

The following table shows responses to the Init command (x=16<cr>).

Table 3-10: Initializing the anyfeed

Terminal Window	Explanation
m11<cr>	Motor/Drive 1 understood command and is now busy, indicated by the second '1'
m21<cr>	Motor/Drive 2 understood command and is now busy, indicated by the '1'
m10<cr>	Motor/Drive 1 completed action successfully, indicated by '0'
m20<cr>	Motor/Drive 2 completed action successfully

### Feeding Parts Forward

The following table shows responses to the Feed Forward command (x=1<cr>).

Table 3-11: Feeding Parts Forward

Terminal Window	Explanation
m11<cr>	Motor/Drive 1 understood command and is now busy, indicated by the second '1'
m21<cr>	Motor/Drive 2 understood command and is now busy, indicated by the '1'
m20<cr>	Motor/Drive 2 completed action successfully, indicated by '0' In feed commands the 'dispense drive' does not execute a motion, but still confirms that it accepted the command and is 'alive'. A consistent drive reporting scheme is easier to handle by the receiving control device.
m10<cr>	Motor/Drive 1 completed action successfully, indicated by '0'

## Changing the Feed Forward Repetitions

The following table shows responses to the command "Set number of turns for Feed Forward motion to 8" (ab[1]=8<cr>).

Table 3-12: Set the number of turns for Feed Forward

Terminal Window	Explanations
	When setting number of repetitions (=turns) the anyfeed does not respond with its standard answers. As stated in the section "anyfeed Responses" only the echo is returned.

## Changing the Flip speed/intensity

The following table shows responses to the command "Set Flip speed/Intensity to 6" (ab[21]=6 x=21<cr>).

Table 3-13: Set Flip speed/Intensity

Terminal Window	Explanation
m11<cr>	Drive 1 command understood
m21<cr>	Drive 2 command understood
m20<cr>	Drive 2 finished
m10<cr>	Drive 1 finished

## anyfeed not Initialized

The following table shows responses to the Feed Forward command (x=1<cr>) before the anyfeed has been initialized.

Table 3-14: anyfeed not Initialized

Terminal Window	Explanation
m16<cr>	Drive 1 reports that it is not initialized
m26<cr>	Drive 2 reports that it is not initialized

## Servo Problem on Flip Drive

The following table shows responses to the Flip command (x=5<cr>) when the flip drive has a servo problem.

Table 3-15: Flip Drive has a Servo Problem

Terminal Window	Explanation
m11<cr>	Drive 1 command understood
m21<cr>	Drive 2 command understood
m20<cr>	Drive 2 reports end of motion
m13<cr>	Drive 1 reports a servo error

## Servo Problem on Disp Drive

The following table shows responses to the Dispense command (x=6<cr>) when the disp drive has a servo problem.

Table 3-16: Disp Drive has a Servo Problem

Terminal Window	Explanation
m11<cr>	Drive 1 command understood
m21<cr>	Drive 2 command understood
m23<cr>	Drive 2 reports a servo error
m17<cr>	Drive 1 stops and reports an error state on Drive 2

## Unknown Command

The following table shows responses to an unknown command, for example (x=9<cr>).

Table 3-17: Unknown Command

Terminal Window	Explanation
m12<cr>	Drive 1 reports that an unknown command was received
m22<cr>	Drive 2 reports that an unknown command was received

## 4. Maintenance – anyfeed SXM100, SXM140 and SXM200

### 4.1 Introduction

**NOTE:** This chapter refers to the anyfeed-models SXM100, SXM140 and SXM200.



**WARNING:** Only qualified service personnel may install or service the anyfeed.

This chapter describes:

- The periodic maintenance required for the anyfeed
- The replacement procedure for the feed surface

### 4.2 Periodic Maintenance

The following tables shows the periodic (routine) maintenance tasks required for the anyfeed.

*Table 4-1: Periodic Maintenance*

Item	Description	Interval
Feed surface	Clean upper side of feed surface and frame with a non-abrasive, no-residue cleaner, such as rubbing alcohol or window cleaner. Failure to do this may degrade vision performance.	Weekly
Feed surface and support	Remove feed surface and clean bottom side with a non-abrasive, no-residue cleaner, such as rubbing alcohol or window cleaner. Clean support surface and glass window with alcohol. Failure to do this may degrade vision performance.	Monthly
Backlight	Remove side panel and clean upper side of backlight. Failure to do this may degrade vision performance.	Quarterly
Servo valve	Check the two plastic silencers that are screwed into the servo valve to see if they are blocked with oil. If needed, replace the silencers. Failure to do this may degrade anyfeed performance.	Annually

**NOTE:** Maintenance intervals may require adjustment based on environment and/or application conditions. If you are feeding dirty parts or if bulk parts contain debris, you may need to shorten the maintenance interval in order to maintain optimum performance of the equipment.

### 4.3 Removing and Installing the Feed Surface

The feed surface is subject to wear during normal system use and will need to be replaced periodically. To replace the feed surface:



**WARNING:** Follow proper lockout procedures before performing this service procedure. Failure to do so could result in injury.

1. Purge all parts from the anyfeed.
2. Turn off the power and air supply to the anyfeed.
3. Remove the feed surface by sliding it out of the rear end of the anyfeed.
4. After the existing feed surface has been removed, clean all residue from the exposed feed deck.



**CAUTION:** Use only a non-abrasive, no-residue cleaner, such as rubbing alcohol or window cleaner applied to a clean shop towel. Do not spray cleaner directly onto the feed deck.

- a. Spray the cleaning product onto a clean shop towel.
  - b. Wipe the feed deck with the shop towel to remove any dirt or debris.
5. Unpack the new feed surface.
  6. Slide the new feed surface into the feed deck.
  7. Turn on the power and air supply to the anyfeed.

## 5. Maintenance – anyfeed SX160, SX240 und SX340

### 5.1 Introduction

**NOTE:** This chapter refers to the anyfeed-models SX160, SX240 und SX340.



**WARNING:** Only qualified service personnel may install or service the anyfeed.

This chapter describes:

- The periodic maintenance required for the anyfeed
- The replacement procedure for the feed surface
- The settings for the retainer speed

### 5.2 Periodic Maintenance

The following tables shows the periodic (routine) maintenance tasks required for the anyfeed.

*Table 5-1: Periodic Maintenance*

Item	Description	Intervall
Feed surface	Clean upper side of feed surface and frame with a non-abrasive, no-residue cleaner, such as rubbing alcohol or window cleaner. Failure to do this may degrade vision performance.	Weekly
Feed surface and support	Remove feed surface and clean bottom side with a non-abrasive, no-residue cleaner, such as rubbing alcohol or window cleaner. Clean support surface and glass window with alcohol. Failure to do this may degrade vision performance.	Monthly
Backlight	Remove side panel and clean upper side of backlight. Failure to do this may degrade vision performance.	Quarterly
Servo valve	Check the two plastic silencers that are screwed into the servo valve to see if they are blocked with oil. If needed, replace the silencers. Failure to do this may degrade anyfeed performance.	Annually

**NOTE:** Maintenance intervals may require adjustment based on environment and/or application conditions. If you are feeding dirty parts or if bulk parts contain debris, you may need to shorten the maintenance interval in order to maintain optimum performance of the equipment.

### 5.3 Removing and Installing the Feed Surface

The feed surface is subject to wear during normal system use and will need to be replaced periodically. To replace the feed surface:



**WARNING:** Follow proper lockout procedures before performing this service procedure. Failure to do so could result in injury.

1. Purge all parts from the anyfeed.
2. Turn off the power and air supply to the anyfeed.
3. Loosen the screws on the side rails.
4. Remove the feed surface by sliding it out of the rear end of the anyfeed
5. After the existing feed surface has been removed, clean all residue from the exposed feed deck (see following figure).



Figure 5-1: Feed Deck and Drive Block



**CAUTION:** Use only a non-abrasive, no-residue cleaner, such as rubbing alcohol or window cleaner applied to a clean shop towel. Do not spray cleaner directly onto the feed deck.

- a. Spray the cleaning product onto a clean shop towel.
  - b. Wipe the feed deck with the shop towel to remove any dirt or debris.
6. Unpack the new feed surface.
  7. Slide the new feed surface into the feed deck.
  8. Re-tighten the screws on the side rails.

9. Turn on the power and air supply to the anyfeed.

## 5.4 Retainer Speed Settings on anyfeed SX160/SX240

The retainer speed can be manually set (see following figure).

The necessary steps are described in this section.

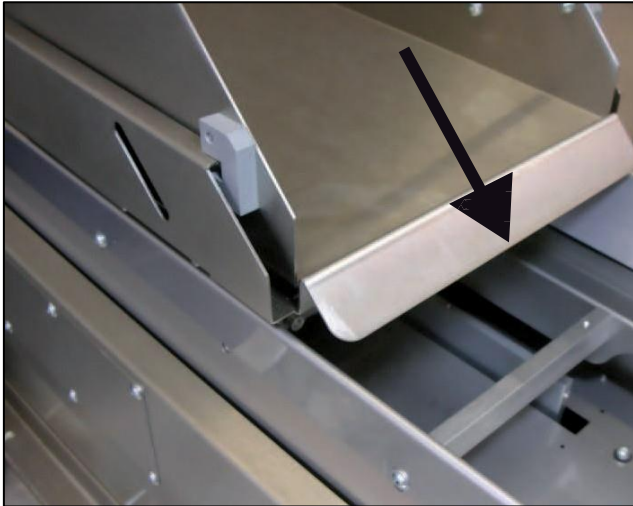

Figure 5-2: Retainer

1. Pull out the feed surface from the back of the feeder (see Section 5.3). Loosen the three screws on both sides of the bulk container to move it aside
2. The interior of the feeder is now accessible (see following figure). You can now increase the speed of the retainer (clockwise) or decrease (counterclockwise) by turning the rotary knob regulator shown in Figure 5-3.

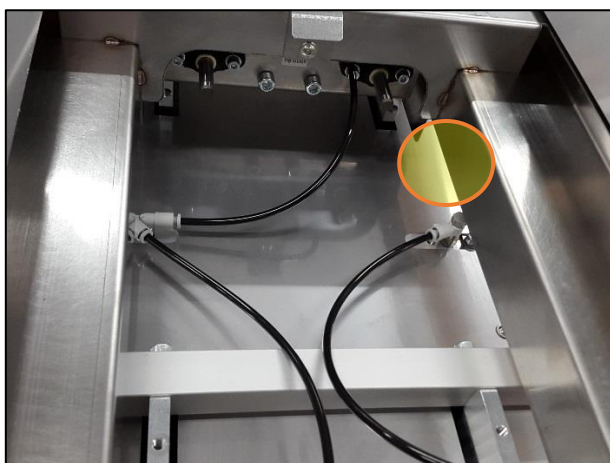

Figure 5-3: Rotary Knob Regulator

3. To check if you achieved the required speed you have to remove the back plate of the feeder (see following figure). Loosen the four screws shown in this figure. To actuate the retainer, push the blue valve (see Figure 5-5) with a pen or similar object. For this test the pneumatic line must be connected to the anyfeed. Reinstall the back plate.

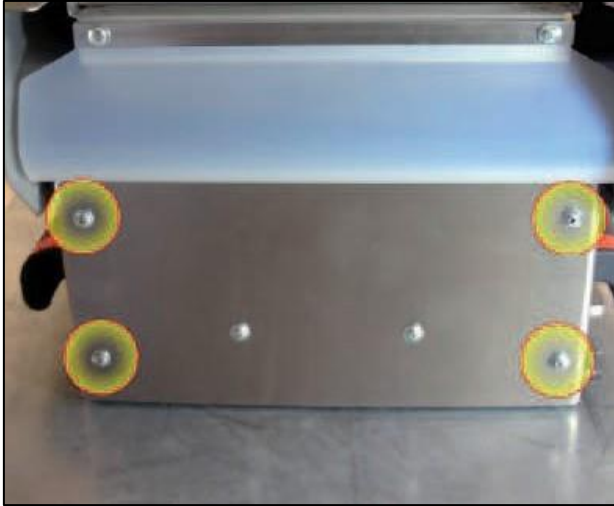

Figure 5-4: anyfeed Back Plate



Figure 5-5: Valve Block

## 5.5 Restraint Setting on anyfeed SX340

The restraint speed can be manually set (see following figure).

The necessary steps are described in this section.



Figure 5-6: Restraint

1. You can increase (clockwise) or decrease (counterclockwise) the speed of the restraint by turning the screw shown in Figure 5-7.



Figure 5-7: Rotary Knob Regulator

2. To check if you achieved the required speed you have to remove the back plate of the feeder (see the following figure 5-8). Loosen the four screws shown in this figure. To actuate the restraint, push the blue valve with a pen or similar object (see the following figure 5-9). For this test the pneumatic line must be connected to the anyfeed. Reinstall the back plate.

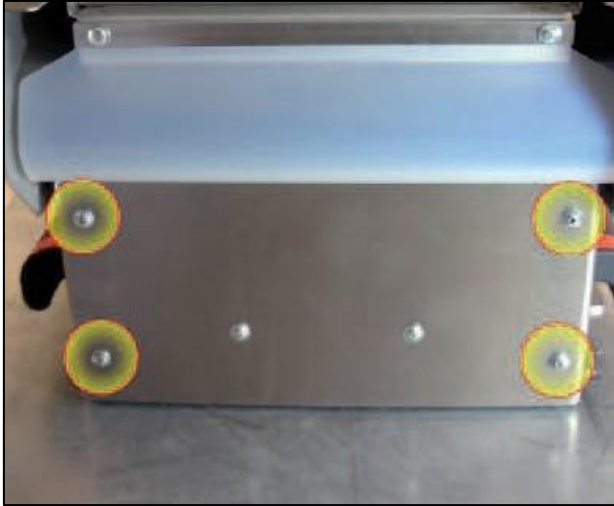

Figure 5-8: anyfeed Back Plate

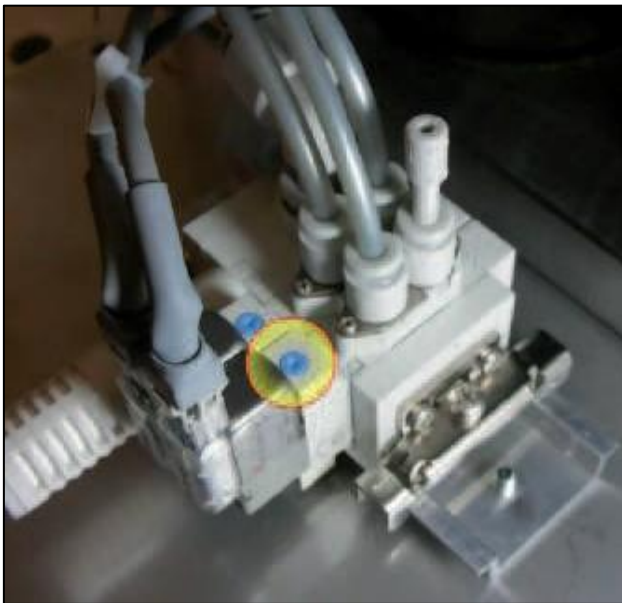

Figure 5-9: Valve Block

## 6. Backlight

### 6.1 Introduction

An optional infrared (IR) or red backlight is available for the anyfeed models.

This section describes the procedure for installing the backlight option exemplary on the anyfeed SX240.

Table: 6-1: Part numbers of the different backlights

Part number IR	Part number red	for anyfeed
900-000-072	900-000-367	SX100
900-000-215	900-000-346	SXM140
900-000-163	900-000-366	SX160
900-000-158	900-000-238	SX240
900-000-235	900-000-373	SX340



**WARNING:** Turn off and disconnect power before proceeding and protect against unintentional reconnection.

### 6.2 Preparing the Installation

1. Slide out the feed surface at the back of the anyfeed as shown in section 5.3.
2. Remove the two screws of the feed platform front cover using a 2.5mm Allen key.



Figure 6-1: Removing feed platform front cover

3. Loosen the 3 front screws of the V-rails that clamp down the feed plate, on each side of the feed platform.



Figure 6-2: V-rails on each side of the feed platform

4. Push the V-rails slightly outwards and lift out the transparent FOV-support plate using a screwdriver at the notch.

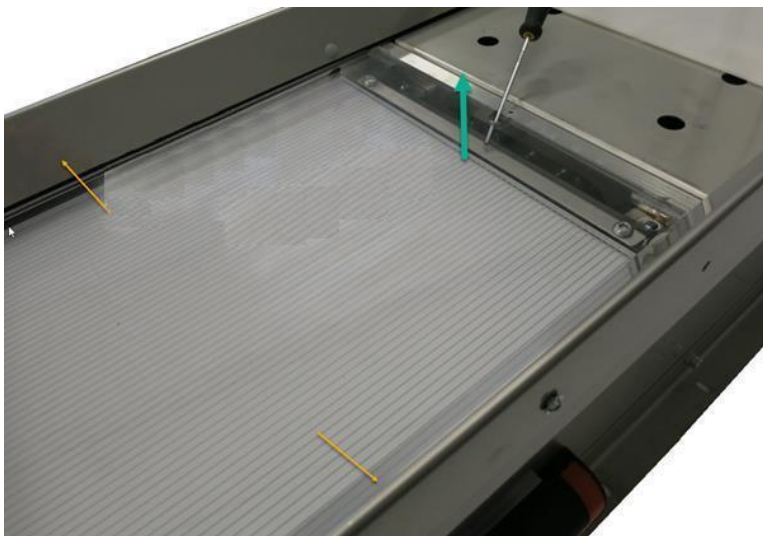

Figure 6-3: Removing the transparent FOV-support plate

## 6.3 Installing the LED Controller

If your feeder was shipped without backlight and integrated LED controller you have to install the LED controller to operate the backlight.

1. Remove the two screws shown in the following figure. The cable connected to the LED controller is located on the bottom of the cover plate. Disconnect the cable from the cover plate.

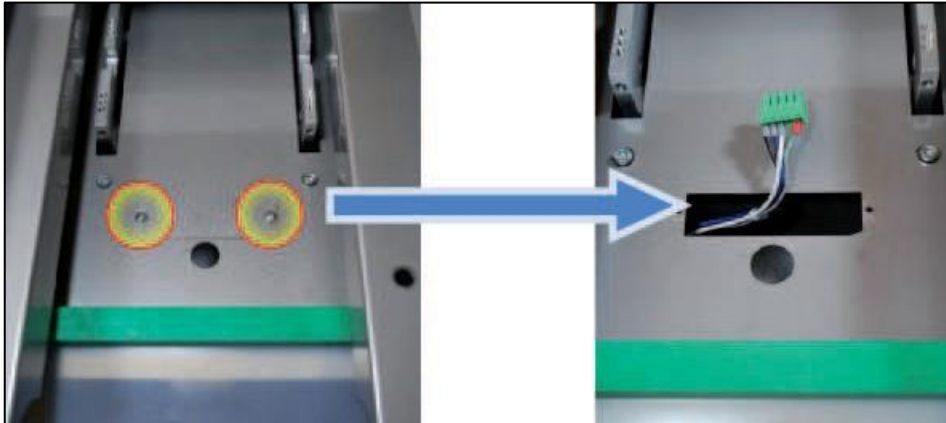

Figure 6-4: Cover Plate on Feed Deck (left), Cable to the LED Controller (right)

2. Connect this cable to the connector of the LED controller.

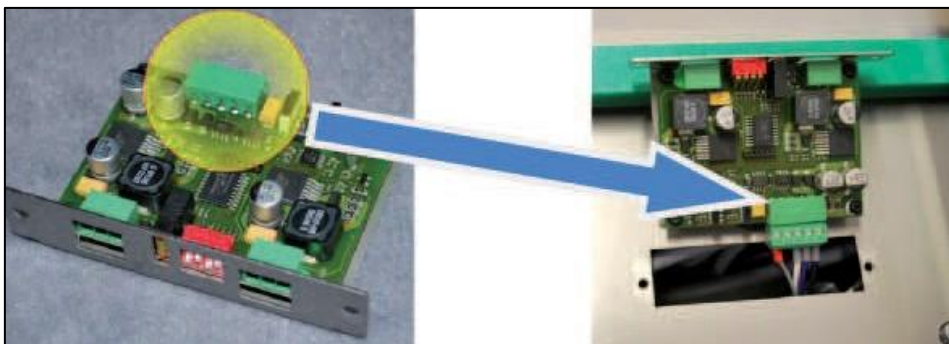

Figure 6-5: LED Controller mounted on bracket (left), LED Controller and connector (right)

- 3. Insert the LED Controller into the slot. Make sure the two switches (see Figure 6-6.) do not accidentally get switched. Then mount the Controller with the two screws.



Figure 6-6: Switches on LED Controller



Figure 6-7: LED Controller (installed)

## 6.4 Installing the Backlight

1. Insert the backlight (cable side ahead) about halfway in the slot at the front of the feed platform. Connect the backlight plugs to the connectors of the LED controller and attach the cable tie base as shown in the following figure. If necessary, degrease the mounting surface before.



Figure 6-8: Inserting Backlight

2. Push the backlight all the way to the back and mount it with the four screws in the corners of the backlight. Tighten the screws with a 2.5mm Allen key.

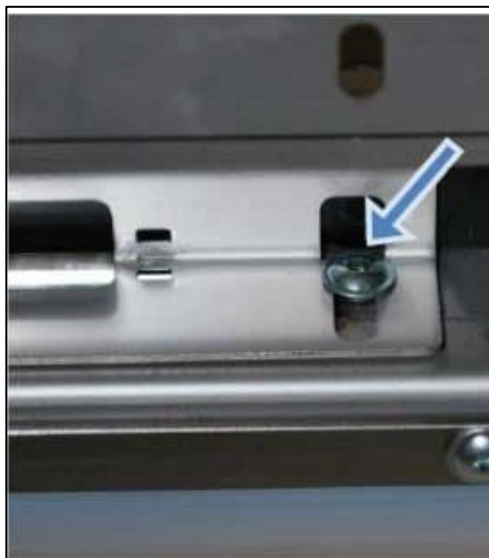
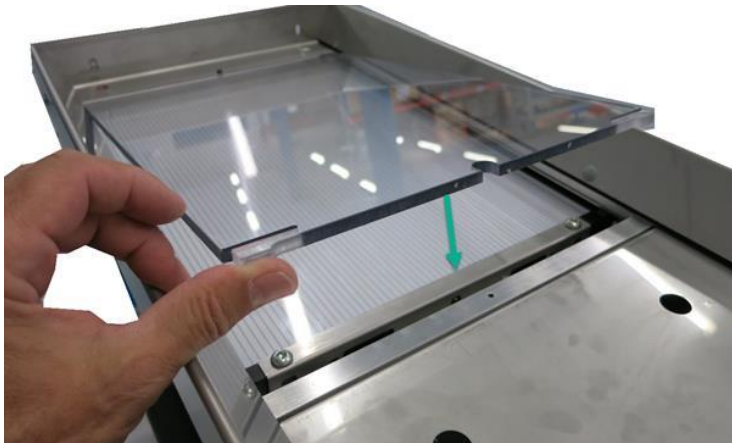

Figure 6-9: Installing the backlight screws

3. Insert again the transparent FOV-support plate as shown in figure 6-10.



*Figure 6-10: insert the transparent FOV-support plate*

4. Mount and tighten the screws of the two V-rails on each side of the feed platform.



*Figure 6-11: V-rails on each side of the feed platform*

5. Slide in the feed surface at the back of the anyfeed as shown in section 5.3 and mount the front cover at the feed platform with the two screws.

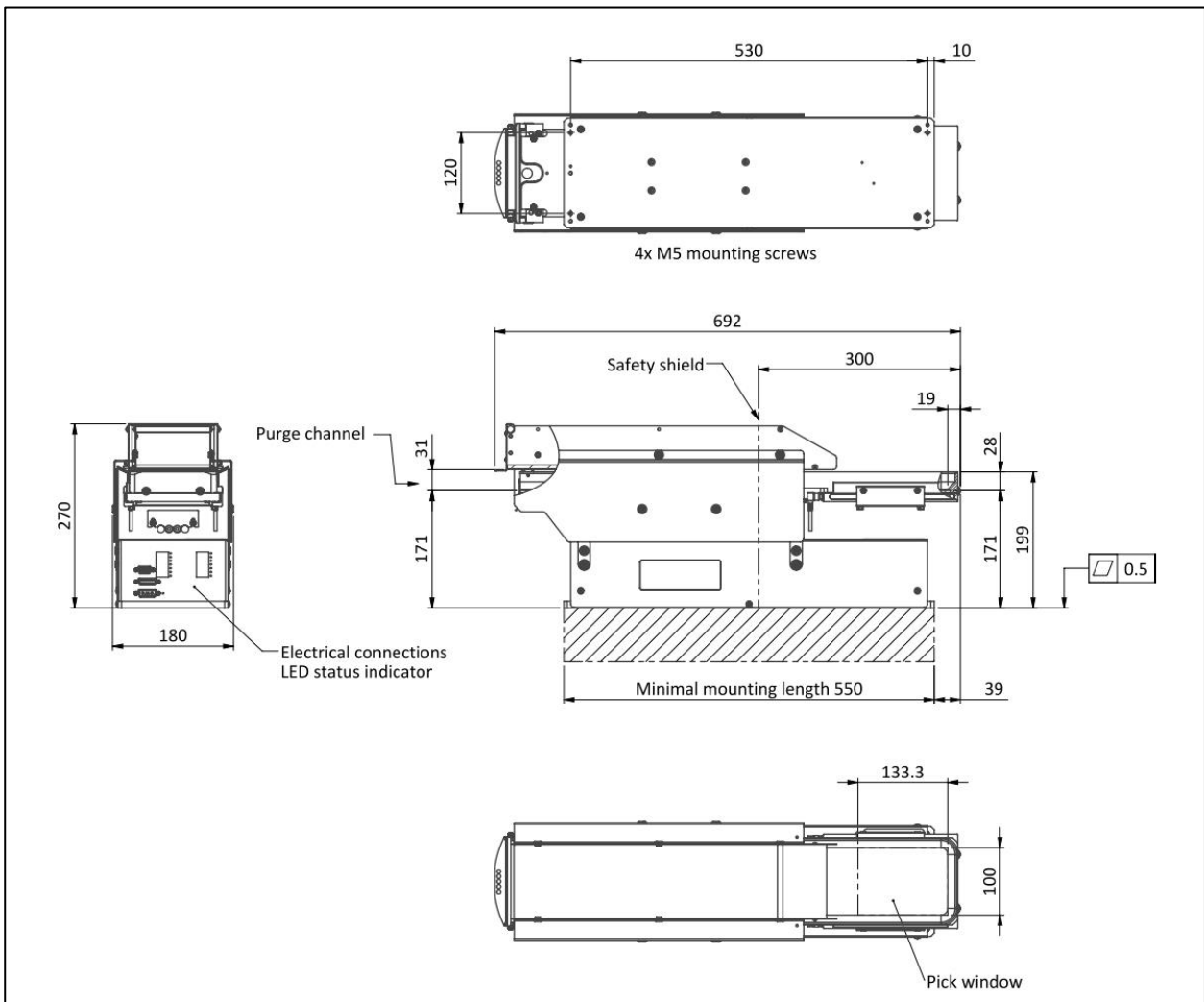

Figure 6-12: Front cover of the feed platform

## 7. Technical Specifications

### 7.1 Dimensions

#### anyfeed SXM100



# anyfeed SXM140

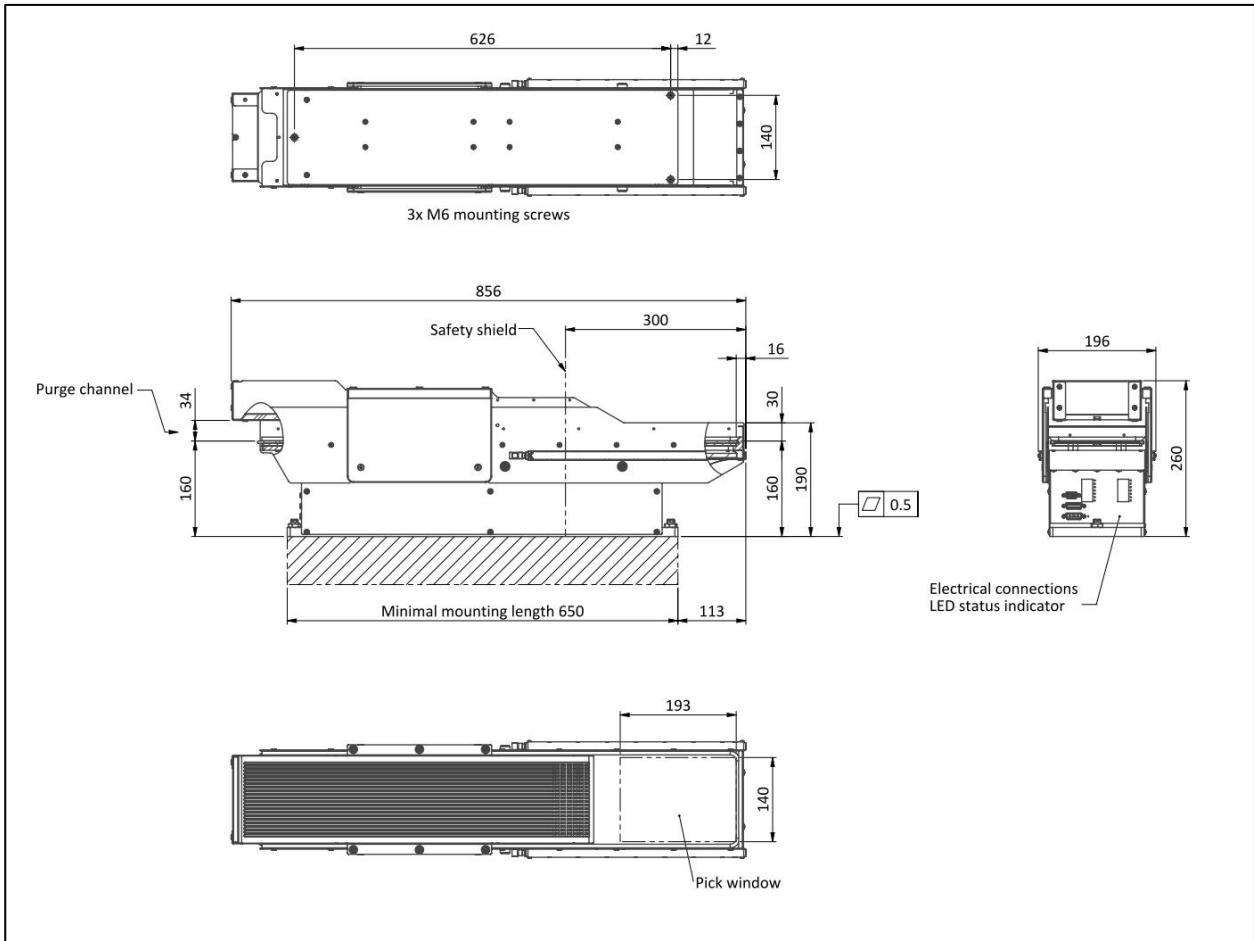

# anyfeed SX160

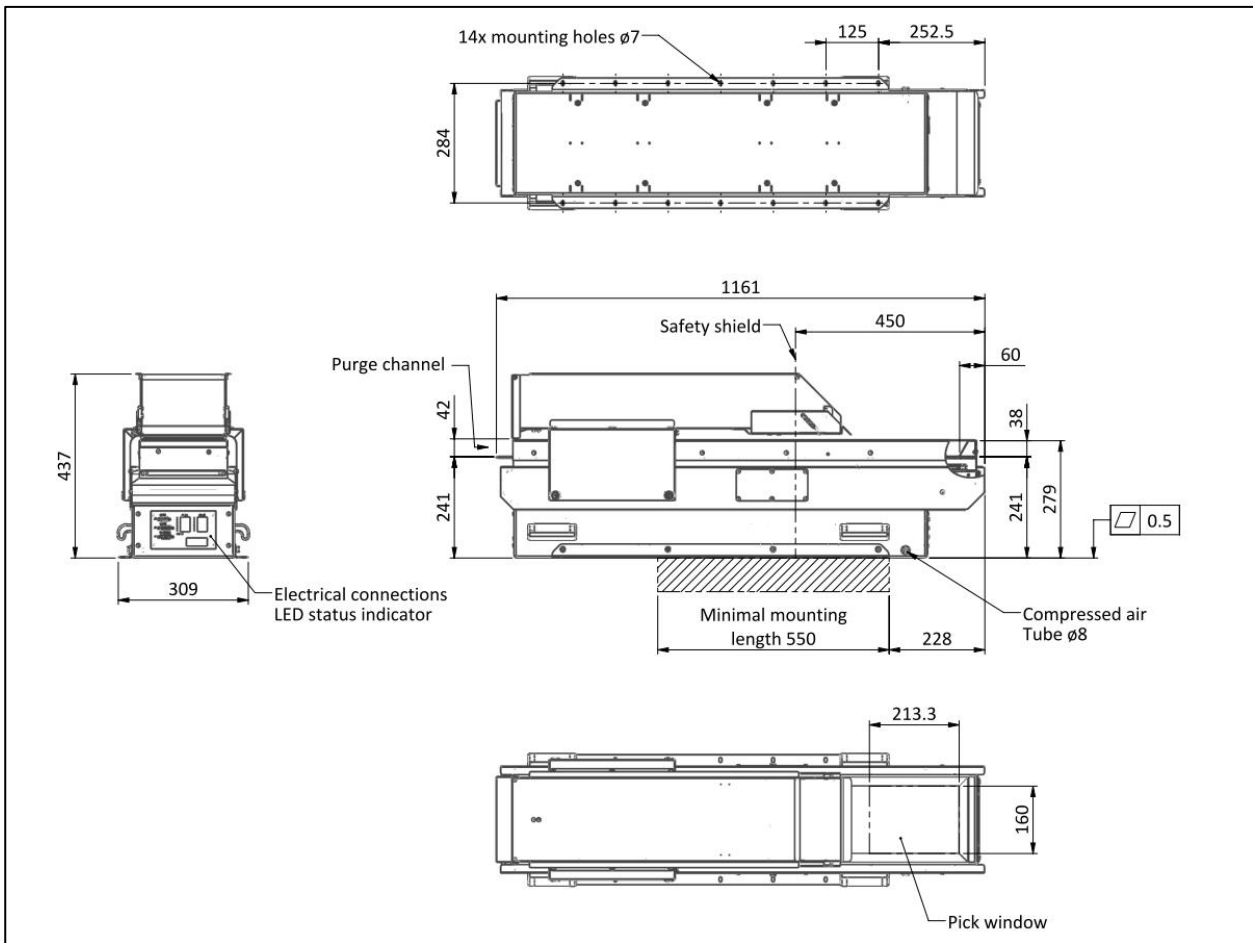

# anyfeed SX240

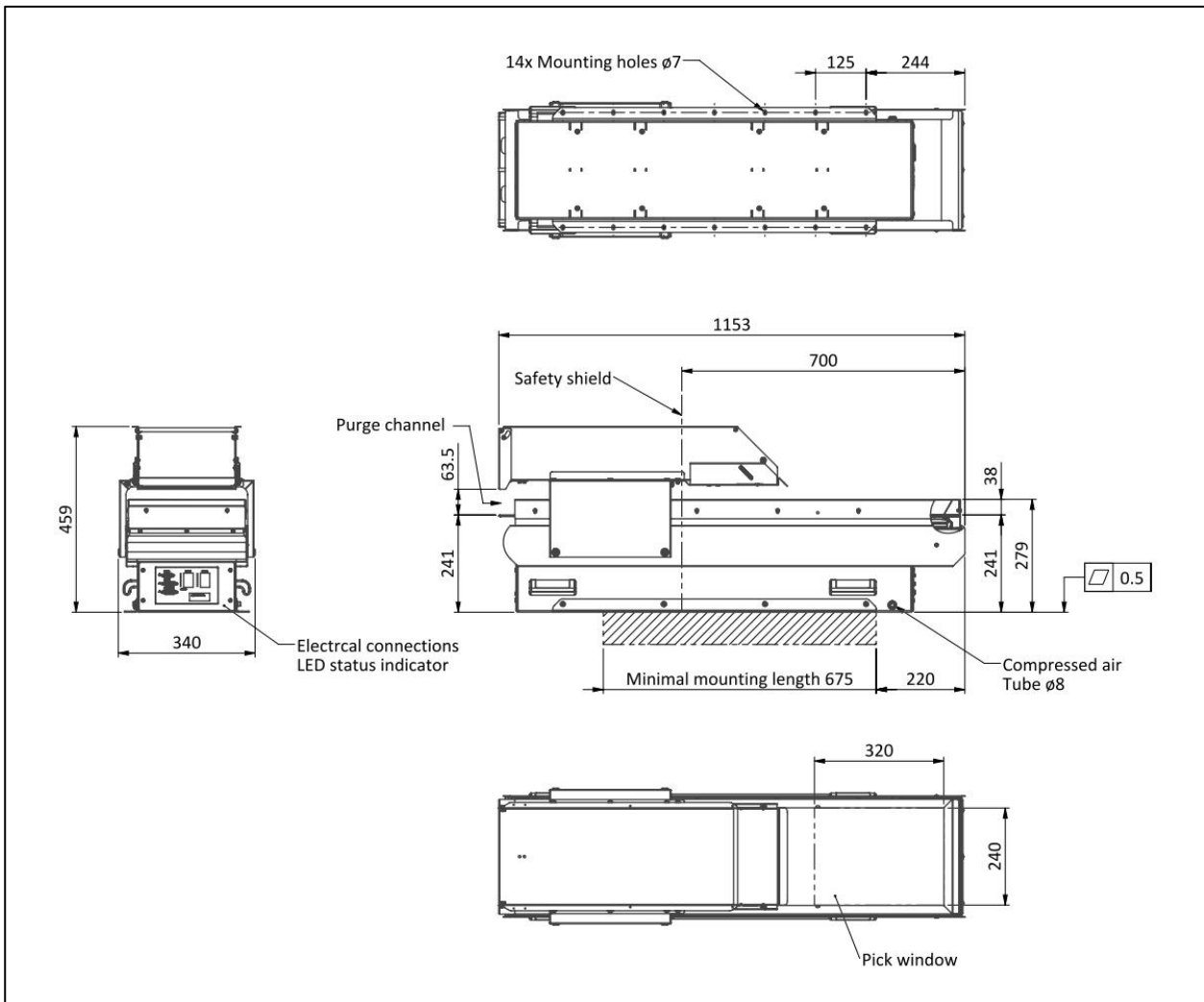

# anyfeed SX340

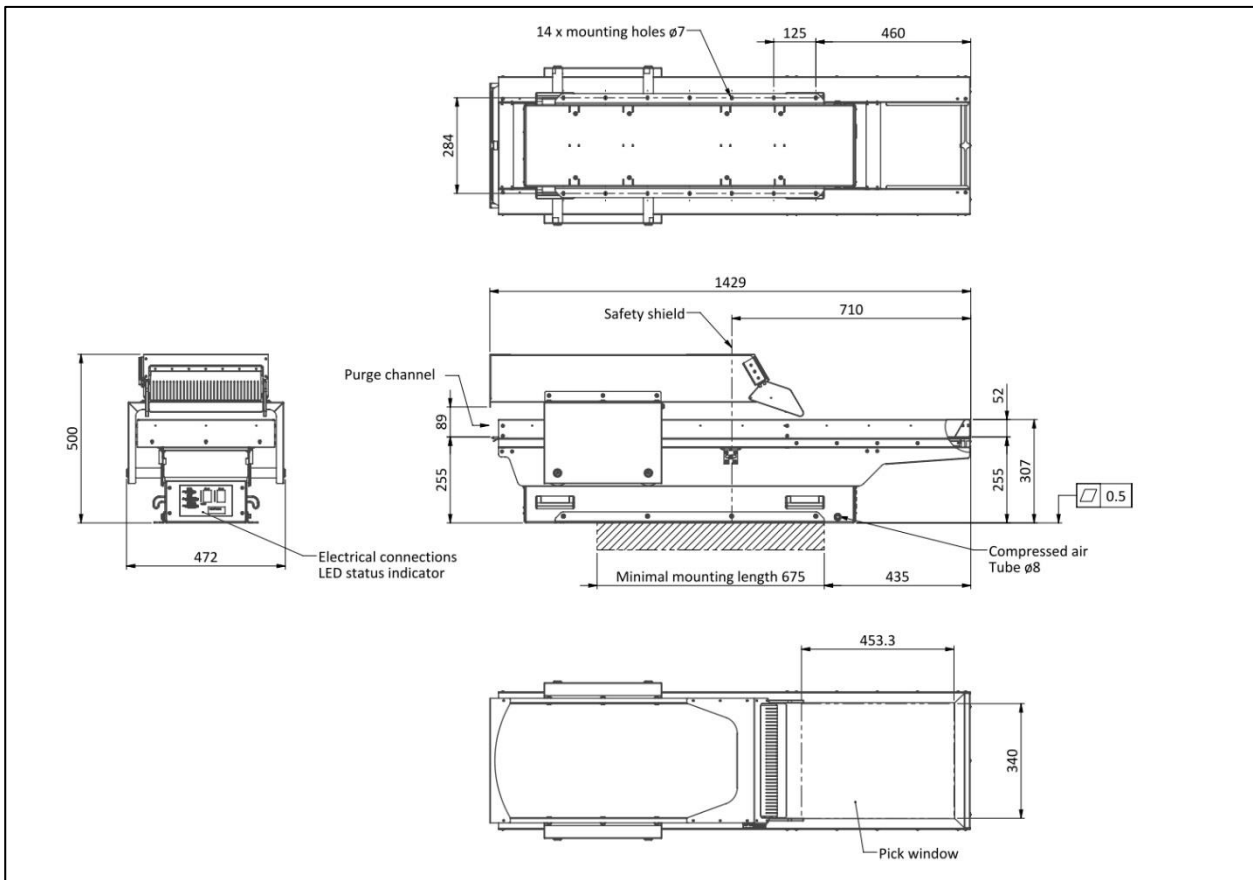

## 7.2 Specifications

	SXM100	SXM140	SX160	SX240	SX340
Capacity Bulk Container	3 dm3	4 dm3	10 dm3	10 dm3	15 dm3
Field of Vision	100x134 mm	140x193mm	160x214 mm	240x320 mm	340x430 mm
Backlight Area	134 cm2	270 cm2	342 cm2	768 cm2	1462 cm2
Max. weight on surface (FOV)	500g	500g	1500g	1500g	1500g
Plate level (parts)	171mm	160mm	241mm	241mm	255mm
Border height	28 mm	28 mm	38 mm	38 mm	52 mm
Light height of Purge Channel	34 mm	34 mm	63.5 mm	63.5 mm	89 mm
Power Requirements	24 V/ 10 A				
Typical consumption	100 W (depending on operating mode)				
Compressed Air	-	-	≤ 6 bar unlubricated / filtered	≤ 6 bar unlubricated / filtered	≤ 6 bar unlubricated / filtered
Eccentricity Feed Surface (Maximum stop from initial position)	± 2 mm	± 3.5 mm	± 12 mm	± 12 mm	± 12 mm
Eccentricity Bulk Container	± 2 mm	± 2 mm	± 5 mm	± 5 mm	± 5 mm
Interface	RS232 (DSUB9 Female)				
Drive	2 brushless servo drives				
Temperature	5-45 °C				
Humidity	95 % non-condensing				
Weight	18 kg	22 kg	48 kg	50 kg	55 kg