

Autor Peter Ulrich  
Datum 08.01.2026  
Version XQ 1.3  
Translation of the original  
Assembly instructions  
Art-Nr.: 007-007-113 D

flexfeeder XQ185, XQ250, XQ350

# Assembly Instructions

In accordance with EC Machinery Directive  
2006/42/EG, Appendix II B

flexfactory AG  
Giessenstrasse 15  
CH-8953 Dietikon

Phone +41 44 774 55 66  
Fax +41 44 774 55 67

info@flexfactory.com  
flexfactory.com



# Table of contents

<b>1</b>	<b>General Information</b>	4
1.1	Information on these instructions	4
1.2	Structure of the warnings	5
<b>2</b>	<b>Safety</b>	7
2.1	Introduction	7
2.2	Responsibility of the operating company	7
2.3	Personnel requirements	8
2.4	Personal protective equipment	9
2.5	Intended use	9
2.6	Residual risks	11
2.6.1	Dangers from electrical energy	11
2.6.2	Mechanical dangers	12
2.6.3	Dangers due to noise	12
2.6.4	Dangers at the place of use	12
2.7	Safety equipment	13
2.7.1	Protective measures at the feeder	13
2.8	Unrecognizable symbols and labels on	13
2.9	Securing against reconnection to electrical power	14
2.10	Shutdown in case of emergency	14
2.11	Environmental protection	14
<b>3</b>	<b>Safety instructions for transportation</b>	15
3.1	Safety	15
3.2	Packaging Crate	15
3.3	Lifting & Moving with a forklift	16
3.4	Transport with crane	17
<b>4</b>	<b>Assembly and installation</b>	18
4.1	Safety	18
4.2	Scope of delivery and functional modules	19
4.2.1	Standard scope of delivery	19
4.2.2	Optional scope of delivery according to customer order	19
4.3	Overview of flexfeeder configurations	20
4.4	<b>Overview of flexfeeder XQ assembly's and functions</b>	21
4.5	Assembly and connection of sensor systems for bulk container	22
4.6	Construction of camera tower with vibration dumping unit	23
4.7	Installation Instructions	24
4.8	Mechanical assembly	26
4.9	Assembly / Change of Feed plate	27

4.10	Assembly of backlight (optional) .....	28
4.11	Electrical installation .....	29
4.11.1	Connecting the Feeder to Power, HW Interface for Emergency & Door handling .....	30
4.11.2	Interfacing Robot, Setup PC, Facility LAN, User Input/Output (UIO) .....	32
4.11.3	Connecting camera tower cables with the feeder controls .....	33
4.12	Control diagram 007-006-627E .....	34
4.13	Preparation of system operating instructions / Safety concept .....	35
<b>5</b>	<b>Establish network connection</b> .....	<b>36</b>
5.1	Network connectors .....	36
5.2	IP-addresses .....	36
<b>6</b>	<b>System tests</b> .....	<b>36</b>
6.1	Initialize the Feeder .....	36
6.2	Test the lighting .....	37
6.3	Test feeder actions .....	37
<b>7</b>	<b>Technical data</b> .....	<b>38</b>
7.1	Dimensions, weight and capacity .....	38
7.2	Electrical supply data .....	38
7.3	Operating conditions .....	38
7.4	Parts requirements for the bulk material .....	39
7.5	Emissions .....	39
<b>8</b>	<b>Maintenance</b> .....	<b>40</b>
8.1	Information .....	40
8.2	Periodic maintenance work .....	40
<b>9</b>	<b>Appendix</b> .....	<b>41</b>
9.1	Declaration of Incorporation .....	41
9.2	Dimension drawing: Base plate mounting pattern .....	42
9.3	Dimension drawing .....	43
9.4	Camera mounting distance (Cognex) .....	47

# 1 General Information

## 1.1 Information on these instructions

These assembly instructions enable the operator to take over, assemble and commission the flexfeeder within the framework of the instructions described here. The basic prerequisite for safe working is compliance with all the warnings and instructions given in these assembly instructions.

<b>i</b>	<b>INFORMATION</b>
	In addition to these Assembly instructions, please refer to the online available step-by-step guides for installation, calibration and product setup. These will guide you through all the necessary steps to integrate the flexfeeder into your system and put it into operation.

Reading Obligation:	Personnel are required to carefully read and understand these installation instructions before beginning any work.
Reselling, Handover:	If the flexfeeder is passed on to third parties, these assembly instructions must also be handed over.
Storage location:	The instructions are an integral part of the machine and must be stored in the immediate vicinity of the machine so that they are always accessible to the relevant personnel.
Additional applicable Documentation:	In addition to these assembly instructions, the flexfeeder instructions, notes and signs in the appendix also apply.
Regulations:	In addition, the local accident prevention regulations and general safety regulations for the area of application of the machine apply.
Figures, Illustrations:	Illustrations in these assembly instructions are for basic understanding and may deviate from the actual design of the machine.
Loss of the Instructions:	If the assembly instructions are lost, Flexfactory AG can request a replacement.

## 1.2 Structure of the warnings

The warnings used in these instructions are introduced by signal words which express the extent of the danger. The warning symbol also indicates the type of danger. The following warnings are used in these instructions:

### Danger level: Risk of death

	<b>DANGER</b>
	<p><b>Risk of death!</b></p> <p>Consequences in case of noncompliance...</p> <p>➔ Notes on avoidance</p>

A warning at this danger level indicates an imminent dangerous situation. Failure to avoid the dangerous situation will result in death or serious injury. Follow the instructions in this warning to avoid the risk of death or serious personal injury.

### Danger Level: Risk of injury

	<b>WARNING</b>
	<p><b>Risk of injury!</b></p> <p>Consequences in case of noncompliance...</p> <p>➔ Notes on avoidance</p>

A warning at this danger level indicates a potentially dangerous situation. Failure to avoid the dangerous situation may result in death or serious injury. Follow the instructions in this warning to avoid the potential risk of death or serious personal injury.

### Danger level: Personal injury

	<b>CAUTION</b>
	<p><b>Personal injury due to...</b></p> <p>Consequences in case of noncompliance...</p> <p>➔ Notes on avoidance</p>

A warning at this danger level indicates a potentially dangerous situation. Failure to avoid the dangerous situation may result in minor or moderate injuries. Follow the instructions in this warning to avoid personal injury.

## Danger level: Damage to property

	NOTICE
	<p>Damage to property due to...</p> <p>Consequences in case of noncompliance...</p> <p>→ Notes on avoidance</p>

A warning at this danger level indicates potential damage to property. If the situation is not avoided, damage to property may occur. Follow the instructions in this warning to avoid damage to property.

## Note on safe working

	SAFETY INSTRUCTIONS
	<p>Safe working during...!</p> <p>Carry out all work in compliance with the safety instructions listed below:</p> <p>→ Notes on safe working</p>

This note contains important information and notes for safe working during the following steps. Follow the instructions in this note to avoid accidents and injury.

## Note on useful information

	NOTE
	<p>Tote text...</p> <p>Follow</p>

A note indicates additional information that is important for the further processing or that simplifies the described work step.

## 2 Safety

### 2.1 Introduction

This section provides an overview of all important safety aspects for the optimum protection of personnel and for safe and smooth operation. Noncompliance with handling instructions and warnings provided in these instructions can result in significant dangers. In these instructions, only those risks can be considered that have been identified based on a risk assessment. Risks resulting from the working conditions, the location of use and interfaces to external components must be identified and warnings must be supplemented accordingly.

### 2.2 Responsibility of the operating company

- Basic information:** The operating company is generally subject to the legal requirements for occupational safety, since the machine is intended for use in the commercial sector. In addition to the warnings in these instructions, the applicable safety, accident prevention and environmental protection regulations for the area in which the machine is used must therefore also be observed.
- Risk assessment:** The operating company must, by means of a risk assessment, inform itself about the applicable occupational health and safety regulations and identify additional dangers resulting from the specific working conditions at the machine's place of use.
- Operating instructions:** According to the results of the risk assessment at the workplace, the operating company must issue, implement and document a set of operating instructions. During the entire operation of the machine, the operator is responsible for ensuring that the operating instructions that it has prepared comply with the current legal requirements.
- Responsibilities:** The operating company must regulate the responsibilities for work on or with the machine and designate a person responsible for ensuring the safe operation of the machine and the coordination of all activities.
- Information flow:** The operating company must ensure that all personnel who perform work on or with the machine have read and understood these instructions and other operating instructions. In addition, it must train the assigned personnel at regular intervals and inform them about the relevant hazards.
- Personal protective equipment:** The operating company must provide the relevant personnel with the required personal protective equipment.
- Safety material:** The operating company must provide all necessary safety materials, such as a padlock to secure the main switch, during maintenance.
- Safety requirements:** If necessary, the operating company must ensure that the machine into which this product is to be integrated or of which it is a component complies with the essential safety requirements and provisions of all relevant directives prior to commissioning.

## 2.3 Personnel requirements

### General personnel requirements:

Only persons who reliably conduct their work and whose ability to react is not impaired by the influence of, for example, drugs, alcohol or medication, may be assigned as operating personnel.

When selecting personnel, the job-specific age specifications applicable at the location where the machine is operated must be observed.

**Qualifications:** Improper handling due to insufficient qualification can result in significant injuries.

- Have all activities conducted by qualified personnel only
- Keep unqualified personnel away from the danger zones

**Qualified personnel:** Qualified personnel can be able to perform the work assigned to them due to their technical training, knowledge and experience as well as their knowledge of the relevant standards and regulations, and to independently identify and avoid possible dangers.

**Qualified electrician:** Qualified electricians can be able to perform the work assigned to them due to their technical training, knowledge and experience as well as their knowledge of the relevant standards and regulations, and to independently identify and avoid possible dangers.

Qualified electricians are trained for the specific location in which they work and know the relevant directives, standards and regulations.

**Forklift driver:** A forklift driver is at least 18 years of age and can drive industrial trucks equipped with a driver's seat or driver's platform due to his or her physical, mental and character traits. In addition, the forklift driver has been trained to drive industrial trucks equipped with a driver's seat or driver's platform. The forklift driver has demonstrated to the operating company that he or she can drive industrial trucks equipped with a driver's seat or a driver's platform and has subsequently been instructed in writing by the operating company to perform this task.

**Instructed person:** The instructed person has been informed by the operating company about the tasks assigned to him or her and about possible dangers in case of improper behavior.

### Unauthorized personnel:

Unauthorized personnel who do not satisfy the requirements described here are not aware of the dangers in the work area.

- Keep unauthorized personnel away from the work area.
- In case of doubt, approach the people concerned and direct them away from the work area.
- Stop work if unauthorized personnel are present in the work area.

## 2.4 Personal protective equipment

Some work requires personnel to use personal protective equipment in order minimize health hazards. In addition to the personal protective equipment specified in these instructions, the notes posted in the work area must be observed. The following personal protective equipment must be worn accordingly before beginning the respective tasks:



### Appropriate work clothing

is tight-fitting work clothing with low tear resistance, tight sleeves and no protruding parts. It is primarily used for protection against entrapment by moving machine parts. Do not wear rings, chains or other jewelry.



### Safety shoes

are used to protect against heavy falling parts and slipping on slippery surfaces.



### Protective gloves

are used to protect the hands from friction, abrasions, punctures or deeper injuries as well as from contact with hot surfaces.



### Safety goggles

are used to protect the eyes from flying particles and parts.

## 2.5 Intended use

The machine is designed and built exclusively for the intended use described here and must only be operated accordingly:

### Functional description of the flexfeeder

The flexfeeder is a flexible feeding system for bulk parts. It consists of a stock parts hopper with a retaining flap and a vibrating table with discharge function. This enables the rejection of NIO parts and a quick product change on the line. The bulk parts are poured from the hopper onto the conveyor platform where they are distributed as best as possible. The kinematics of the drive allows different movement patterns. Through these, the parts can be moved back and forth, redistributed or turned into. The servo drives allow the movement of light as well as heavy parts.

The flexfeeder is equipped with a Linux-based/embedded controller. The communication between flexfeeder and robot or plant control is done via Ethernet TCP/IP.

The flexfeeder is set up via a browser-based user interface. With only two parameters - intensity and duration of the movement - the conveying behavior can be individually adjusted to the different parts.

**Intended use:** The flexfeeder is designed and constructed exclusively for the intended use described here and may only be operated accordingly:

The flexfeeder

- serves exclusively as a flexible feeding system for bulk material parts for, for example, assembly, testing or packaging machines.
- is intended exclusively for installation in a complete system.
- may only be operated in accordance with the operating and ambient conditions specified in chapter 5 (technical data).
- may only be operated in accordance with the requirements of the locally applicable accident prevention regulations.
- may only be operated with additional protective measures (e.g. machine guarding) during automatic removal of parts from the vibrating table. Together with a collaborative robot, the formwork can be dispensed with, if this is permitted by the risk analysis of the higher-level machine/plant.
- May only be operated with additional protective measures (e.g. safety light grid) when parts are removed manually.

**Improper use:** There is a risk of serious injury or death if the flexfeeder is not used as intended due to:

- Operation in potentially explosive atmospheres
- feeding of unpacked foodstuffs
- operation without lateral fixation on the table

**Urgently avoid the following misuse:**

- Feeding wet, heavily soiled and heavily oily parts.

Claims of any kind due to damage due to improper use are excluded.

## 2.6 Residual risks

The following section lists residual risks that have been identified on the basis of a risk assessment.

	SAFETY INSTRUCTIONS
	<p>Failure to observe the safety instructions, warnings and handling instructions given in these assembly instructions may result in considerable danger.</p> <ul style="list-style-type: none"><li>• <b>It is essential to observe the listed</b> safety and warning notes and instructions for action!</li><li>• <b>Also observe the safety instructions contained in the</b> applicable documents.</li></ul>

### 2.6.1 Dangers from electrical energy

In case of contact with electrically live parts, damage to the insulation or individual components, there is a danger to life due to electric current.

- To be ensured by the operator: The electrical connection of the machine in which the flexfeeder is installed must comply with the electrotechnical regulations.
- Work on the electrical system may only be carried out by qualified electricians.
- In case of damage to the insulation, switch off the power supply immediately and arrange for repair.
- Before connecting the machine to the power supply, compare the data in chapter 5 (technical data) with the data of the power supply system and connect only if there is a match.
- Before starting work on active parts of electrical systems and equipment, ensure that they are de-energized for the duration of the work.
- Never bridge fuses or put them out of operation. When replacing fuses, observe the correct current rating.
- Keep moisture away from electrically live parts. This can lead to a short circuit.

## 2.6.2 Mechanical dangers

Moving assemblies have the potential to cause crushing, shearing and impact injuries. Moving assemblies harbor the potential for injury from crushing, shearing and impact.

- In automatic mode, only operate the machine with installed and functioning protective covers.
- Before maintenance work and troubleshooting, switch off the machine and secure it against being switched on again.
- Operator responsibility: Manual operation of the machine within the machine enclosure is the responsibility of the operator and is subject to the safety concept of the relevant machine or its control system.

## 2.6.3 Dangers due to noise

Depending on the material being conveyed, high noise levels may occur which can cause hearing damage.

- Depending on the material conveyed, wear hearing protection if necessary.
- Operator responsibility: It is the operator's responsibility to take additional measures to protect against noise emissions, if necessary. Possible measures include, for example, the use of special conveyor plates, lining the hopper and the return container, and adjustments to the machine casing (to improve sound insulation).

## 2.6.4 Dangers at the place of use

Safety deficiencies caused by incorrectly performed work due to insufficient lighting.

- Ensure sufficient lighting at the workplace. Have defective lamps replaced immediately.
- Sharp edges, corners, and sharp-edged materials can cause abrasions and cuts on the skin.
- Exercise caution when working near sharp edges and corners and when handling sharp-edged materials.
- If in doubt, wear protective gloves (e.g. when cleaning the machine).
- Dirt and objects lying around are sources of slipping and tripping.
- Always keep the work area clean.
- Remove objects that are no longer needed.
- Mark tripping hazards with yellow-black marking tape.

## 2.7 Safety equipment

Danger due to non-functioning safety devices!

- ✓ Before starting work, ensure that the safety devices are functional and correctly installed.
- ✓ Never disable safety devices.
- ✓ Ensure that safety devices such as the EMERGENCY STOP button are always accessible.
- ✓ The cell protection device is mounted on the machine itself.

	INFORMATION
	The flexfeeder must be integrated into the emergency stop concept of the entire plant.

### 2.7.1 Protective measures at the feeder

Moving components, such as drive units, are either fully enclosed or protective measures have been applied.

The flexfeeder is intended for operation within a safety fence. In case of other use, as described e.g. on page "Intended use", the manufacturer must assess the overall system according to the risks and take suitable measures.

- ✓ The protective covers attached to the flexfeeder must not be modified, dismantled or put out of operation.
- ✓ Protective covers removed during maintenance/repair work must be refitted before recommissioning.
- ✓ Protective covers must always be in place when the feeder is powered on.

## 2.8 Unrecognizable symbols and labels on

Risk of injury from unrecognizable symbols or pictograms on the machine:

- ✓ Ensure that all safety, warning and operating instructions are always clearly legible condition.
- ✓ Replace damaged symbols and pictograms immediately.
- ✓ Never cover, block or remove symbols and pictograms.

Pictograms may be located on the machine. They refer to the immediate environment in which they are located and indicate hazards or measures to be taken.

## 2.9 Securing against reconnection to electrical power

	<b>DANGER</b>
	<p>Risk of serious injury or death due to unauthorized or uncontrolled restarting (e.g. during troubleshooting or maintenance work):</p> <p>Before restarting, make sure that all enclosures and protective covers are mounted and in working order and that there is no danger to persons.</p>

Always follow the procedure described below for securing against restarting.

- ✓ Disconnect the machine from the power supply.
- ✓ Secure the main switch (of the complete system) with a lock or other adequate measures. Observe the information in the operating instructions for the complete system.
- ✓ After all work has been carried out, ensure that there is no danger to people.
- ✓ Ensure that all safety and protective devices are installed and in working order.
- ✓ Only remove the lock from the main switch, after complying with all the points above.

## 2.10 Shutdown in case of emergency

In case of accidents and in case of danger, the machine must be stopped immediately. The emergency-stop circuits of the flexfeeder and the higher-level overall system must be connected to each other. When the emergency stop button on the overall system is pressed, the flexfeeder therefore also goes into emergency stop.

Pressing the emergency stop button triggers an emergency stop.  
Risk of serious injury or death due to uncontrolled restart:

- ✓ Before restarting, make sure that the cause of the emergency stop has been eliminated and that all safety devices are mounted and functional.
- ✓ Only unlock the emergency stop button when there is no longer any danger.

## 2.11 Environmental protection

Danger to the environment due to incorrect handling of environmentally hazardous substances, in particular incorrect disposal, is posed by the following substances used in the flexfeeder:

- ✓ Lubricants such as greases and oils (e.g. In ball bearings) may contain toxic substances. They must not be released into the environment. Disposal must be carried out by a specialist disposal company in accordance with the locally applicable regulations.
- ✓ Replaced machine parts may be contaminated by greases and oils and thus contain toxic substances and must be disposed of professionally.
- ✓ All materials used in the flexfeeder can be disposed of in the usual channels such as: Scrap metal, plastics, electronic components.

### 3 Safety instructions for transportation

#### 3.1 Safety

SAFETY INSTRUCTIONS	
	<p><b>Safe working during the transport of the machine!</b> Perform all work in compliance with the following safety instructions listed below</p> <ul style="list-style-type: none"><li>• Observe the regulations listed in chapter Safety for all work on / with the machine.</li><li>• Observe the instructions and personnel requirements according to chapter Personnel requirements.</li><li>• Provide suitable forklift trucks for transport.</li><li>• Do not step under heavy loads. Instruct unauthorized persons from danger areas.</li></ul>

#### 3.2 Packaging Crate

Crate with feeder-unit only

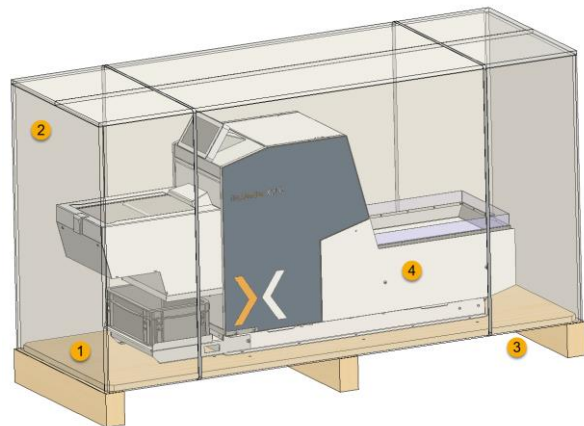

Crate with feeder and camera tower

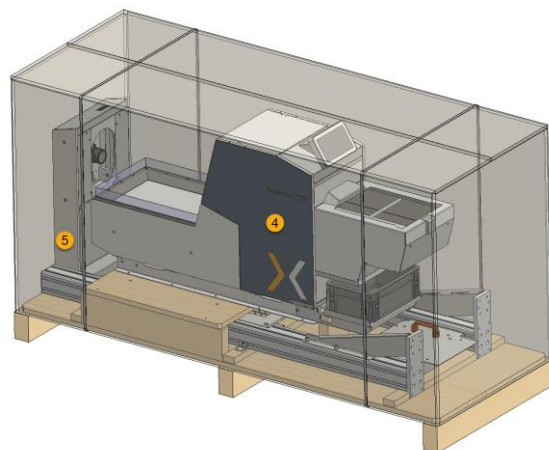

Construction of packaging crate

1	Pallet (wood)
2	Crate (wood)
3	Fixation tape
4	Feeder fixed on the pallet
5	Camera tower fixed on the pallet

### 3.3 Lifting & Moving with a forklift

#### Important

- The center of gravity of the transport unit must be considered. This is +/- 200mm below the middle beam of the wooden pallet.
- The transport locks of the individual components (screws in wooden pallet) may only be removed at the destination.
- The forklift may only be operated by a licensed forklift driver.

#### Transportation

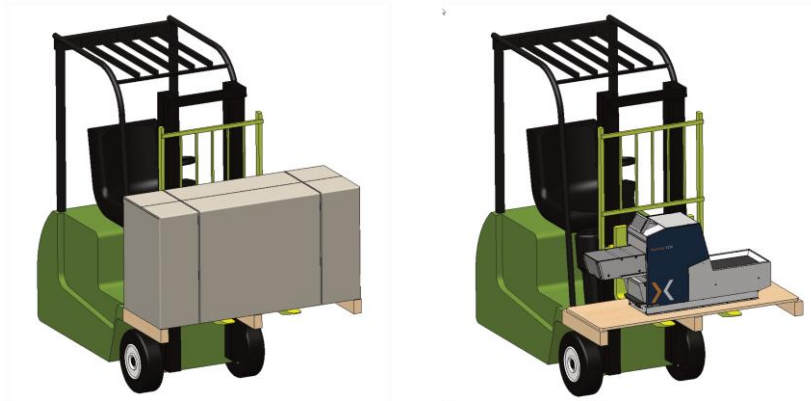

#### Fork alignment



Make sure the forks are 600-800mm apart!

Center the fork pair sideways under the pallet and make sure the fork tips protrude from underneath the pallet.

#### Lifting

Start lifting the pallet slowly. Lift it only as high as needed.

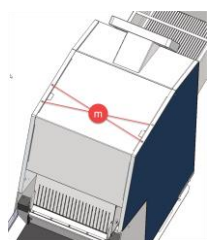

#### Center of gravity

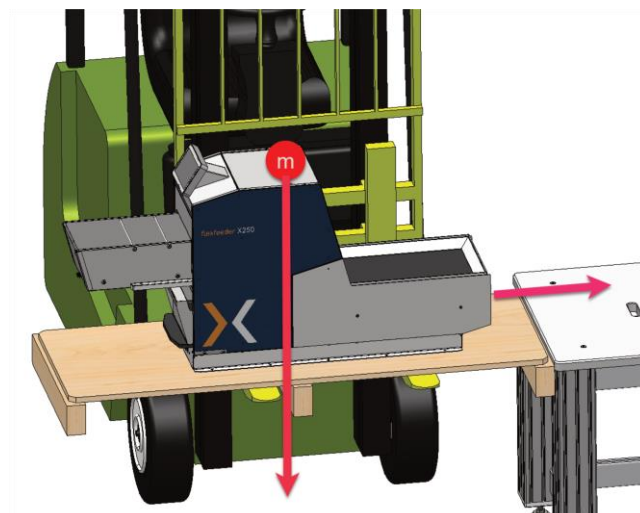

Position the pallet in front of the machine base and level the top of the pallet slightly above the machine base.

Remove the screws which secure the feeder on the pallet.

Carefully push the feeder onto the machine base.

### 3.4 Transport with crane

The flexfeeder can be transported by a crane in compliance with the company's internal regulations:

Prerequisites

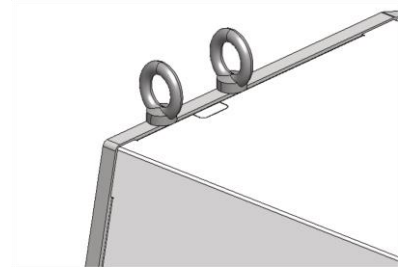
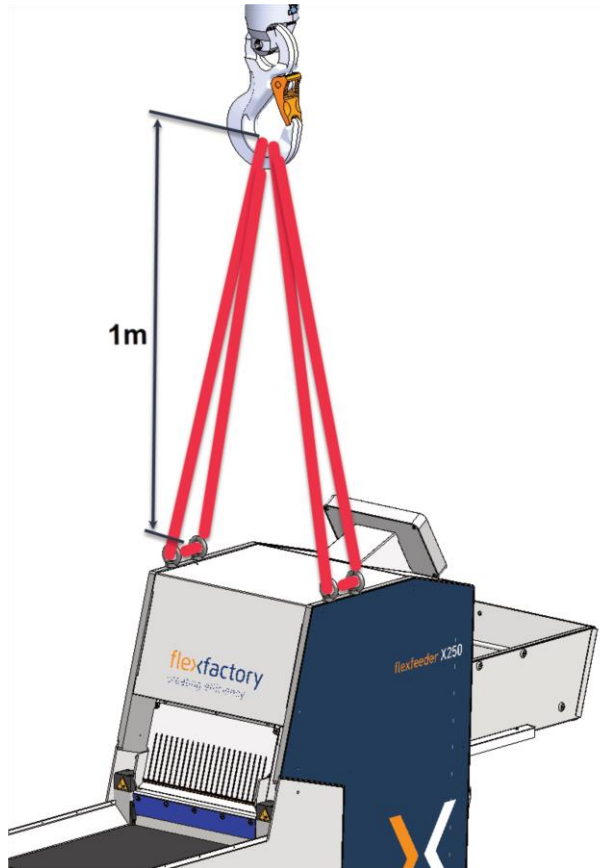

Screw the enclosed 4 eyebolts M6x13 (ISO3266) into the side plate.

Thread the belts into eyebolts or hang them with additional hooks. So that the eyebolts and threads are not overloaded laterally, the hanger must have a minimum distance to the crane hook of 1m.

Ensure that ropes, belts, etc. are not twisted and that the transport pieces are securely fastened.

<b>CAUTION</b>	
	<p>Personal injury due to overloading when lifting loads:</p> <p>If the flexfeeder is lifted manually from the transport pallet, the operator's internal safety regulations must be observed (see weight specifications chapter 5)</p>

## 4 Assembly and installation

### 4.1 Safety

	SAFETY INSTRUCTIONS
	<p>All work must be carried out in compliance with the following safety instructions listed below:</p> <ul style="list-style-type: none"><li>✓ Observe the regulations listed in chapter [? ] for all work on or with the machine.</li><li>✓ All installation work may only be carried out by specially trained personnel (see chapter personnel requirements).</li><li>✓ Work on the electrical system may only be carried out by electrical specialists (see chapter Qualifications).</li><li>✓ For all installation work, wear protective equipment in accordance with the local accident prevention regulations.</li><li>✓ Before starting work, switch off the electrical supply and secure it against being switched on again.</li><li>✓ Before starting work, ensure that there is sufficient space for the installation.</li><li>✓ Ensure tidiness and cleanliness at the installation site! Loose components and tools lying on top of each other are potential sources of accidents.</li><li>✓ Do not step under suspended loads/<b>equipment's</b>.</li></ul>

## 4.2 Scope of delivery and functional modules

Before assembly, the scope of delivery of the machine must be compared with the order documents to check the completeness of the delivery. Immediately report any incomplete or damaged delivery to Flexfactory AG.

### 4.2.1 Standard scope of delivery

- ✓ Flexfeeder consists of a vibration table (Shaker) with return channel, bulk part dispenser, HMI control panel, integrated smart camera for part localizing and providing the coordinates to the robot.
- ✓ Bunker sensor (level monitoring in the bulk container for part-shortage alert or control of an external bulk feeder)
- ✓ Skip-over protection for shaker table
- ✓ Cable 24V power supply, 5m
- ✓ Cable Safety I/O, 5m
- ✓ Cable Ethernet Cat 6, 5m
- ✓ Flexfeeder operating software (factory installed)
- ✓ 4 pcs. eyebolts M6x13

### 4.2.2 Optional scope of delivery according to customer order

- ✓ Camera tower for installation on a base plate  
or
- ✓ Camera module for installation on a cell structure
- ✓ Toplight
- ✓ Fastening kit for Toplight
- ✓ LED backlight (white, red or IR) built into the shaker
- ✓ Dispenser flap unit for bulk containers
- ✓ Feed plate(s) according to customer product requirements
- ✓ Lockable (monitored) bunker cover

### 4.3 Overview of flexfeeder configurations

A flexfeeder system is comprised of

1. Feeder + options
2. Camera + options

and installation accessories (not shown here)

The Toplight shown below is optional.

If an optional backlight was ordered, it is factory installed inside the shaker.

All configurations shown below, are available for the flexfeeder XQ185, XQ250, and XQ350.

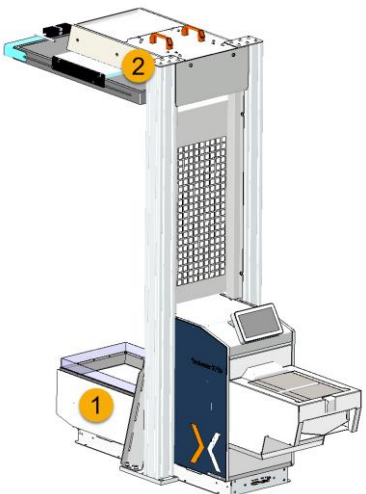
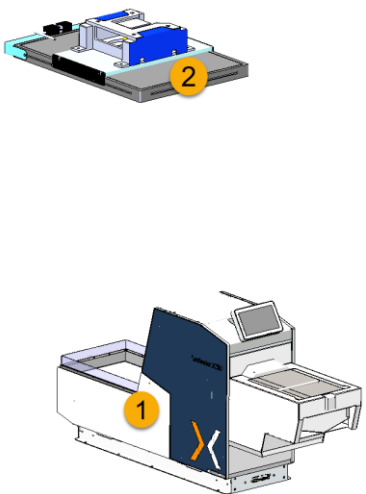
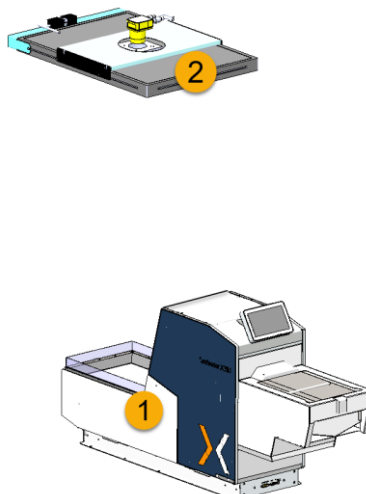
		
<p><b>flexfeeder with Camera Tower</b></p> <p>flexfeeder with camera tower, integrated camera, and Toplight. Feeder and camera tower to be mounted individually to customer's base plate. Cables that connect camera to feeder are factory installed in the tower. If an optional Toplight is part of the order, it comes with a mounting kit so the customer can easily attach it to the tower.</p>	<p><b>flexfeeder with Camera Module</b></p> <p>flexfeeder with camera module and Toplight. The camera module must be mounted to customer's cell framework. Feeder to be mounted to customer base plate. Cables for connecting feeder and camera module and optional Toplight are provided. Routing of cables lies with the customer.</p>	<p><b>flexfeeder with Camera Module</b></p> <p>flexfeeder with separate camera and Toplight. All cables for connecting feeder and camera and an optional Toplight are provided. Routing of cables lies with the customer.</p>

**Based on the shipping papers and the information above, determine which configuration you are about to assemble, install, and test.**

#### 4.4 Overview of flexfeeder XQ assembly's and functions

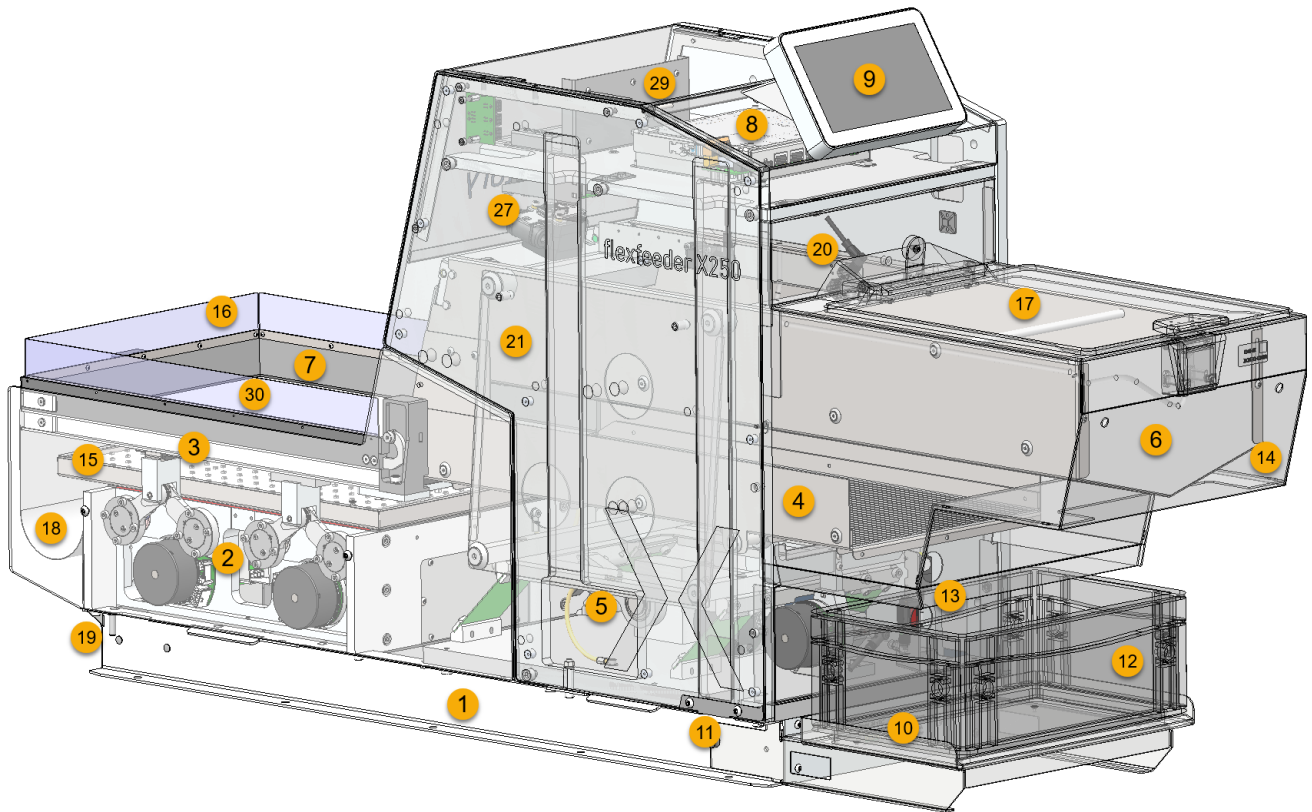

Position	Assembly / function	Option
1	Frame, Mounting rail	
2	Drive Shaker	
3	Vibration table shaker	
4	Return conveyor	
5	Drive bulk dispenser	
6	Bulk dispenser	
7	Feed plate clamp frame	
8	System controller	
9	HMI-Panel with touchscreen	
10	Interface panel 24V-supply, safety signal	
11	Cable duct	
12	Return container including mounting bracket	Option
13	Sensor for return container	Option
14	Rear cover	
15	Backlight	Option
16	Skip-over protection	
17	Bulk bin lid, lockable	Option
18	Front cover	
19	Grounding bolt	
20	Part shortage sensor	
21	Cover (fixed magnetically)	
27	Dispenser flap unit	Option
29	CAN I/O - Interface	
30	Feed plate, according to part requirements	Customized

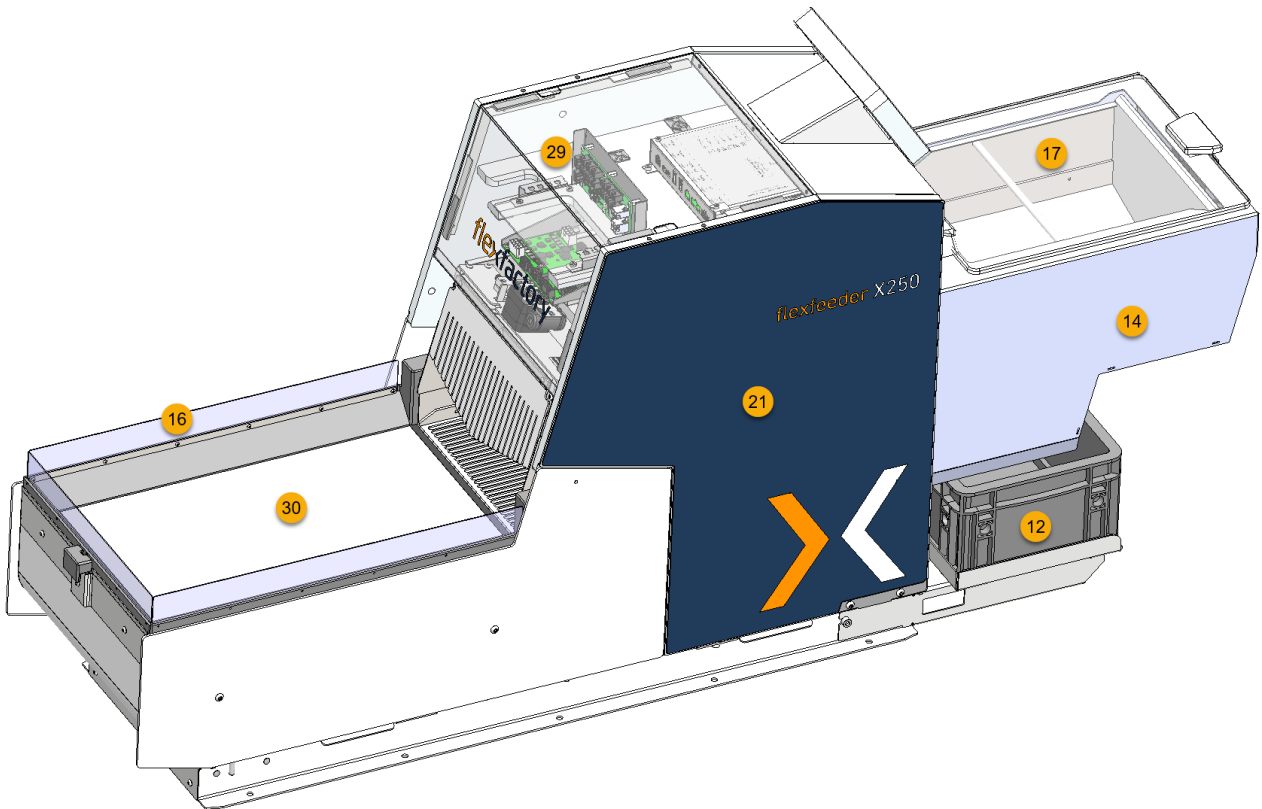

#### 4.5 Assembly and connection of sensor systems for bulk container

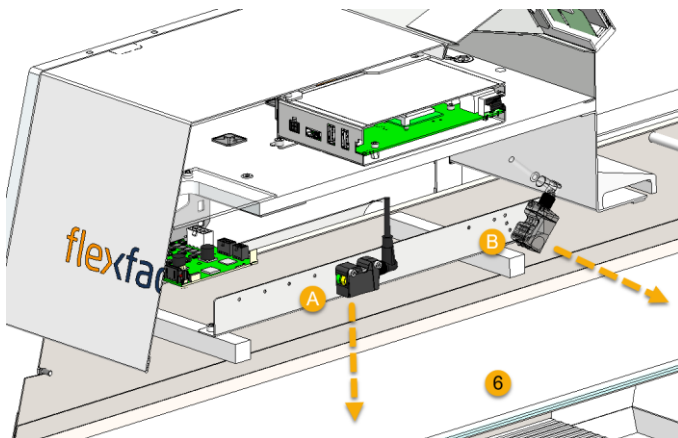

Installation A (standard):

Monitors the bulk material on the outlet side and reports parts shortages.

Installation B for additional external bulk parts feeder:

Monitors the bulk material on the inlet side and reports parts shortages to the external feeder.

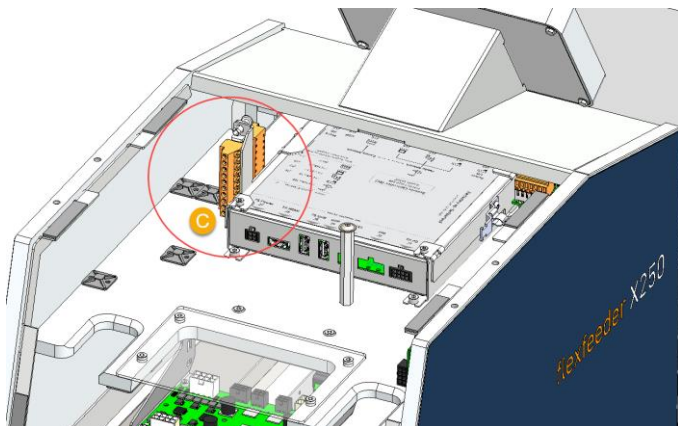

Connection to higher-level control via plug connection C:  
User input / output (UIO)

Pin 2: GND

Pin 3: OUT 'Fill level low' (24V-signal)

See Installation instruction 4.11.2

Control-Diagram, Page 33

## 4.6 Construction of camera tower with vibration dumping unit

Position	Assembly / function	Standard / Option
31	Camera tower	Customized
32	Toplight	Customized
33	Toplight mounting kit	Customized
34	Vibration dampening box	Customized

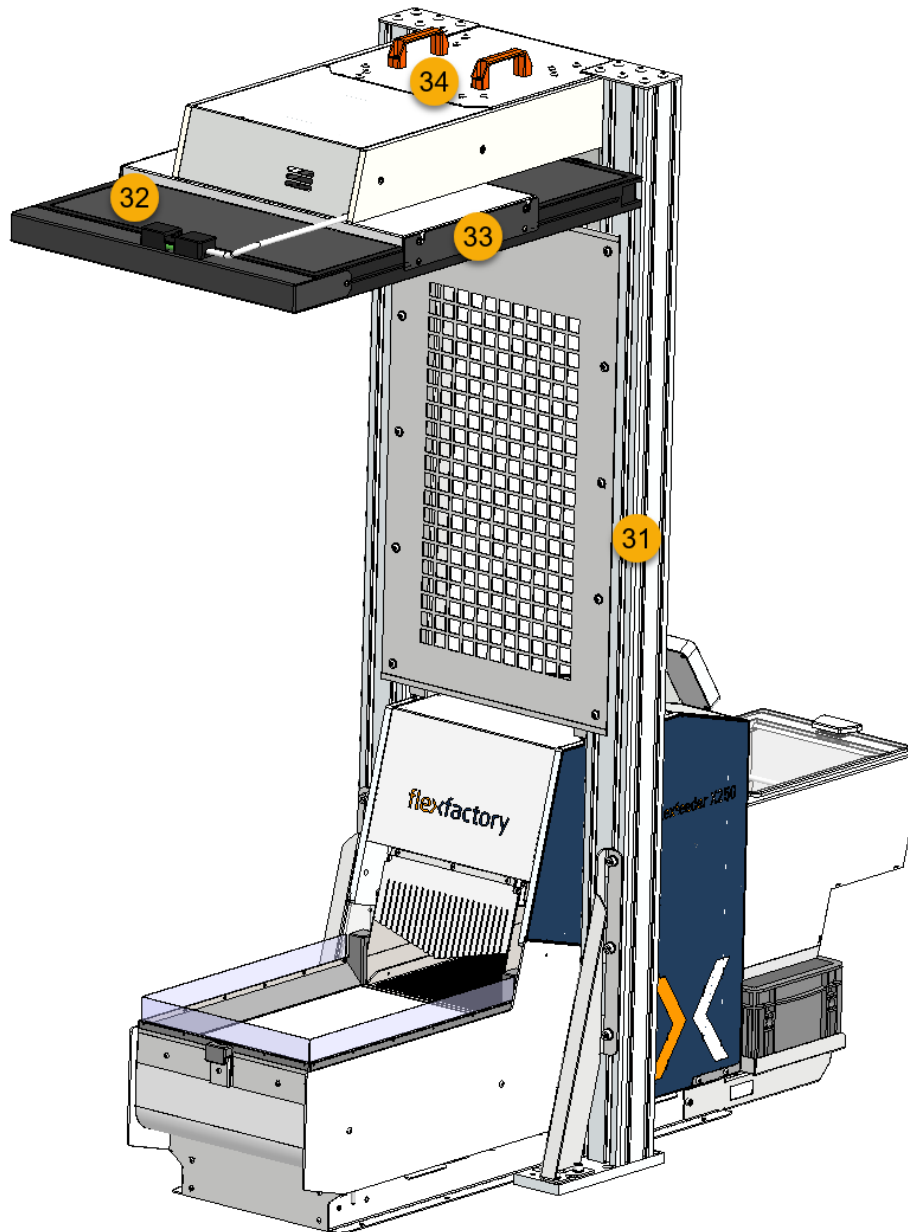

The camera tower (pos 31) is delivered detached from the feeder. The drilling pattern for attaching the feeder and the camera tower can be found in the appendix of these assembly instructions.

The position of the camera tower in relation to the feeder must be maintained.

The vibration damping unit, item 34 is delivered separately and must be installed subsequently in the standing tower.

The vibration damping unit effectively reduces vibrations that comes from the feeder or the robot cell. It is delivered separately and must be installed in the camera module after assembling the camera tower and screwed with the included screws (4) M6x12.

The vibration damping unit may only be operated or stored in a horizontal position. If the camera tower is transported horizontally, the damping unit must not be installed.

4

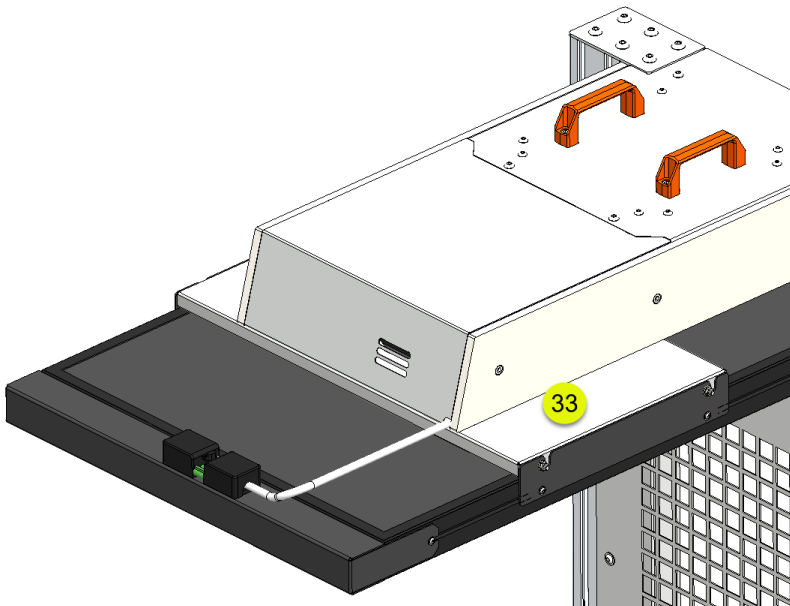

Attaching the Toplight to the camera tower.

The mounting kit (33) is delivered pre-assembled.

See also chapter 4.8, Step 4

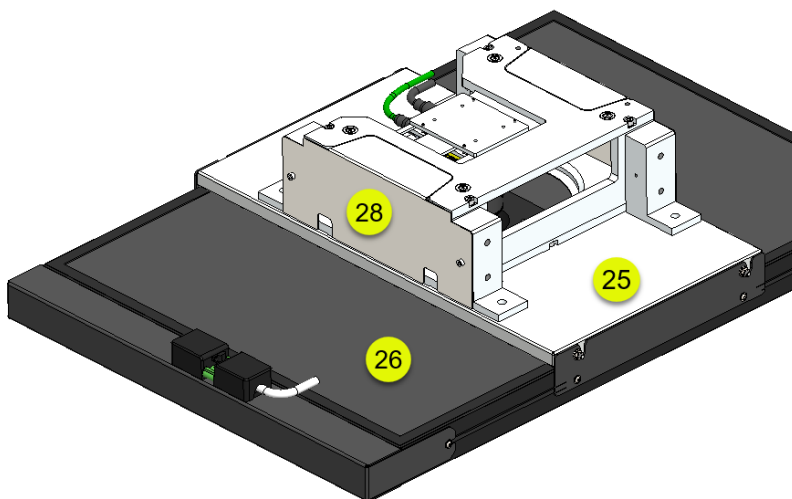

Attaching the Toplight to the camera module.

The mounting kit (25) is delivered pre-assembled.

The attachment of the camera module (28) must be prepared by the customer.

See also chapter 4.8, Step 4

## 4.7 Installation Instructions

<b>WARNING</b>	
	<p><b>Danger due to vibrations</b></p> <ul style="list-style-type: none"><li>• If the feeder is not installed correctly, there are various dangers due to vibrations occurring during operation.</li><li>• The feeder may never be operated without being firmly bolted down to the machine base. The vibrations the feeder generates lead to reaction forces which can move it off the table.</li><li>• Make sure you comply with the safety instructions listed below.</li></ul>



## SAFETY INSTRUCTIONS

- Make sure the machine base is leveled and rests stable on the floor.
- Place the feeder exclusively on metal machine base, made from steel or aluminum. For a steel tabletop plate, we recommend a thickness of at least 15mm, for an aluminum plate at least 20mm.
- The tabletop plate shall have a flatness better than 0.5mm within the footprint of the feeder.
- Secure the feeder on the tabletop with at least 6 M6 steel screws.
- Install a grounding wire between the machine base and the feeder. The feeder comes with a dedicated M6 grounding stud.

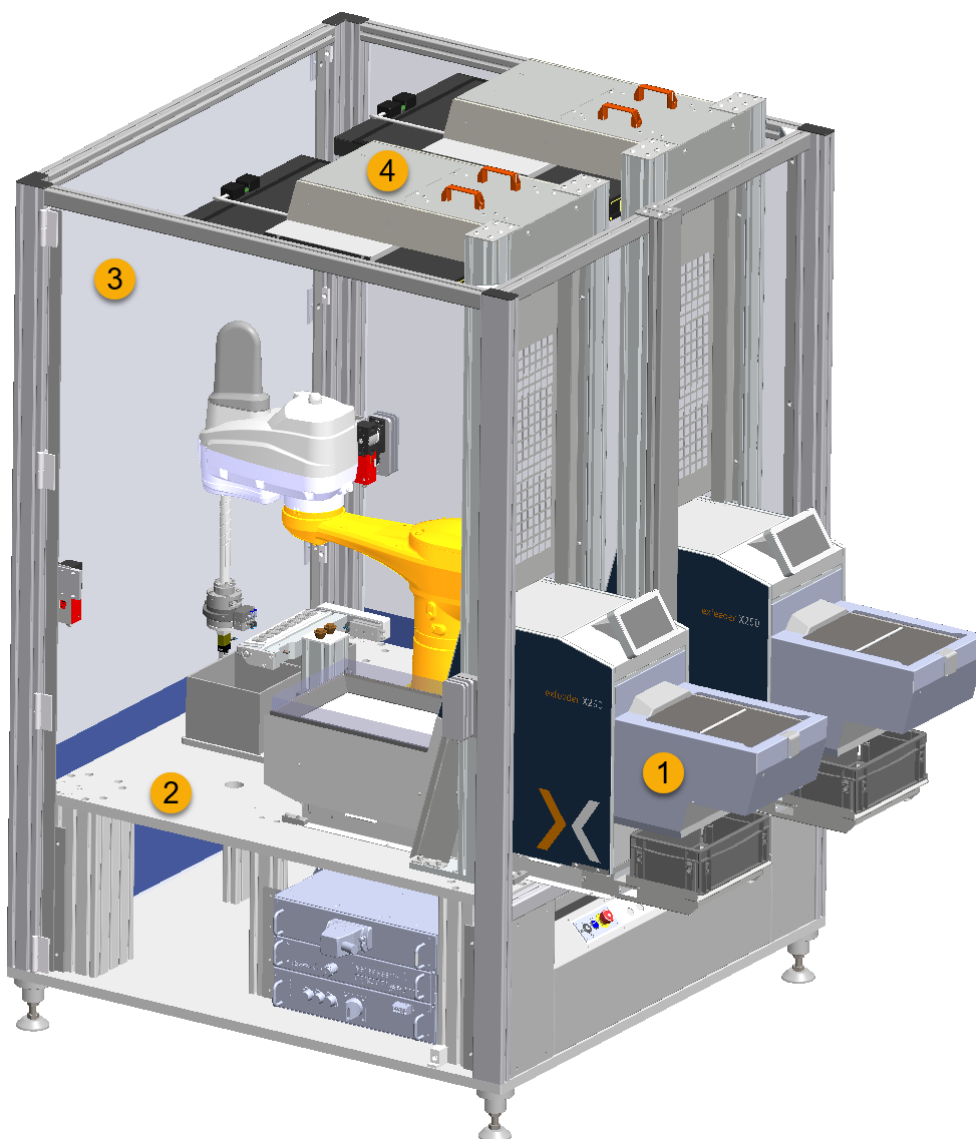

Example of a robot cell with a flexfeeder X

- 1 Flexfeeder
- 2 Heavy duty machine base
- 3 Cell cover
- 4 Camera tower

## 4.8 Mechanical assembly

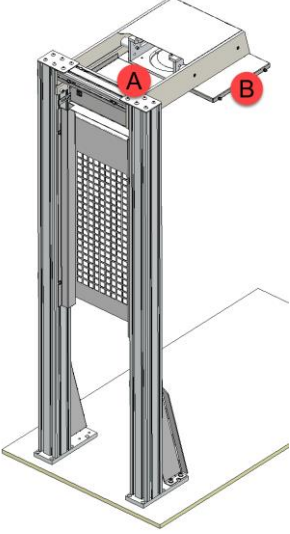
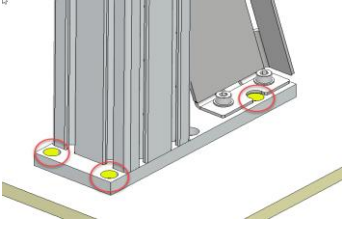
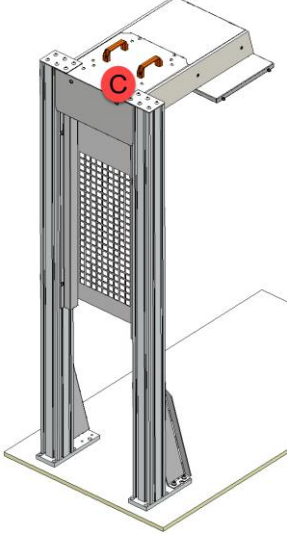
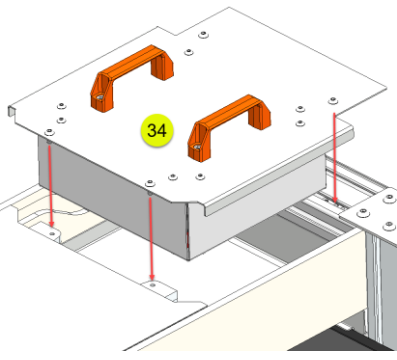
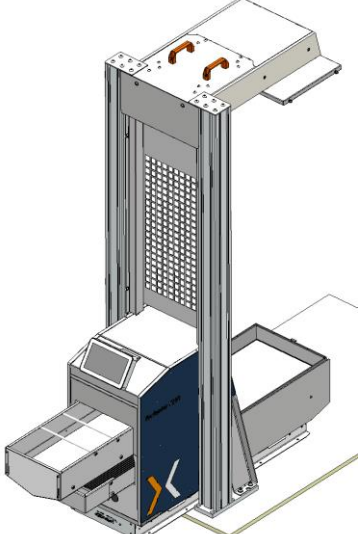
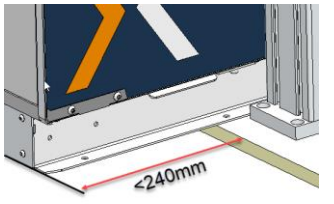
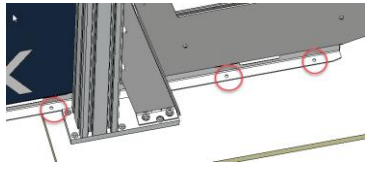
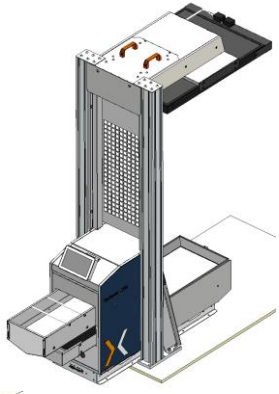
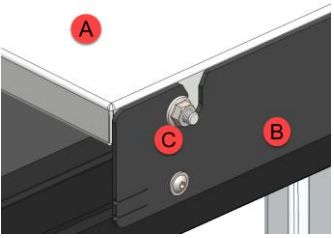
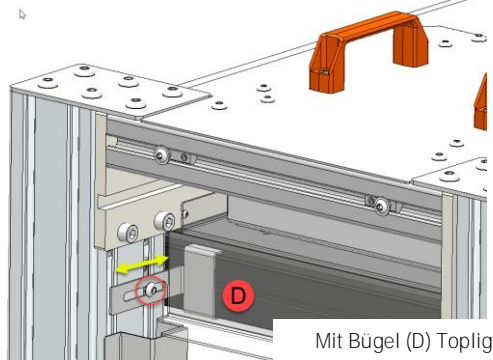
Step 1	Step 2	Step 3
 <p>Place the camera tower on the machine table and screw it tight (5x M8x20, hexagon socket screw) Remove the cover plate at the back side and insert the rolled-up cables (A) backwards into the cable duct.</p>  <p>Mounting kit (B) for Toplight is optionally pre-assembled.</p>	 <p>Insert the vibration damping module (34) in position C and screw it tight.</p> 	 <p>Place the feeder on the machine table and screw it tight on booth side (M8x16, hexagon socket screw)</p>  
<p>Step 4 (optional)</p>   <p>Hang the Toplight with the mounting plate (B) in the mounting kit (A) and fix it with the hexagon nut (C).</p>	<p>Step 5 (optional)</p>  <p>Mit Bügel (D) Toplight fixieren.</p> <div data-bbox="837 1848 1428 2072" style="border: 1px solid black; padding: 5px;"> <p>Important: When manually lifting the flexfeeder, camera tower, damping unit or Toplight, the operator's internal safety regulations must be observed.</p> </div>	

## 4.9 Assembly / Change of Feed plate

Unlock the locking screw (1) and pull the locking spring (2) forward / unlock the bolt

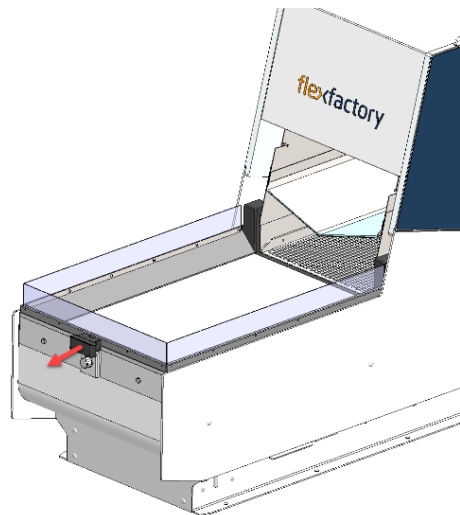
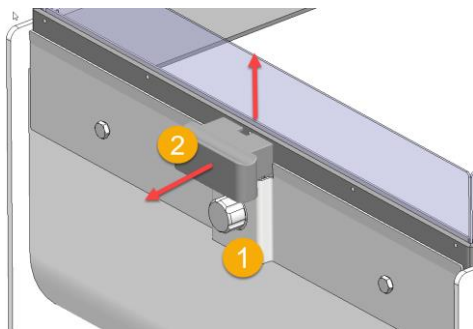

Swing the table frame upwards

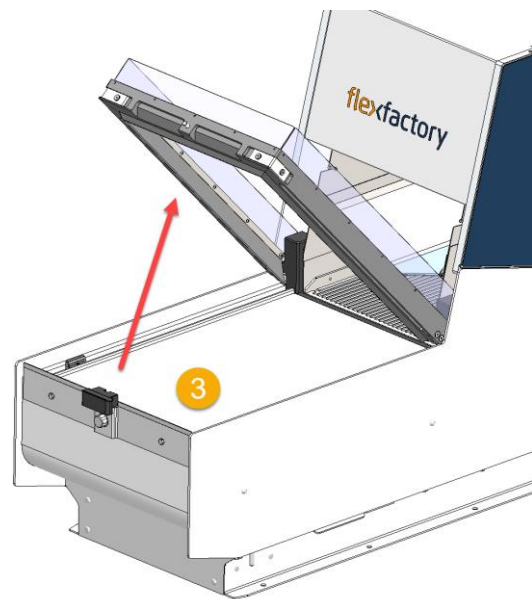

Lift the feed plate (3) and pull it forward

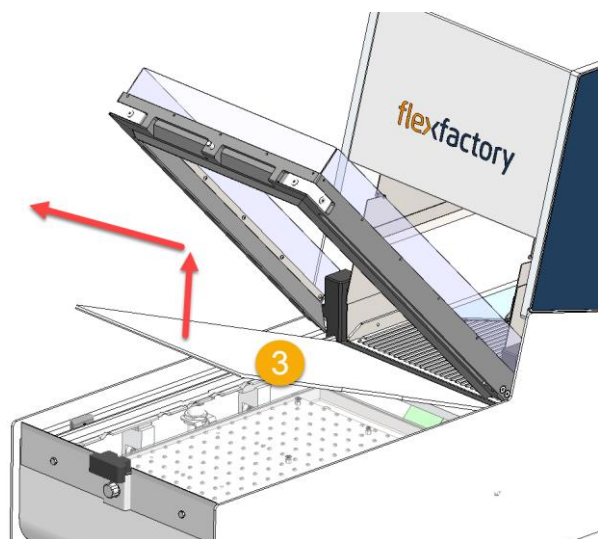

#### 4.10 Assembly of backlight (optional)

Loosen the fastening screws (1) on the front panel (2 turns) and pull the cover below (2)

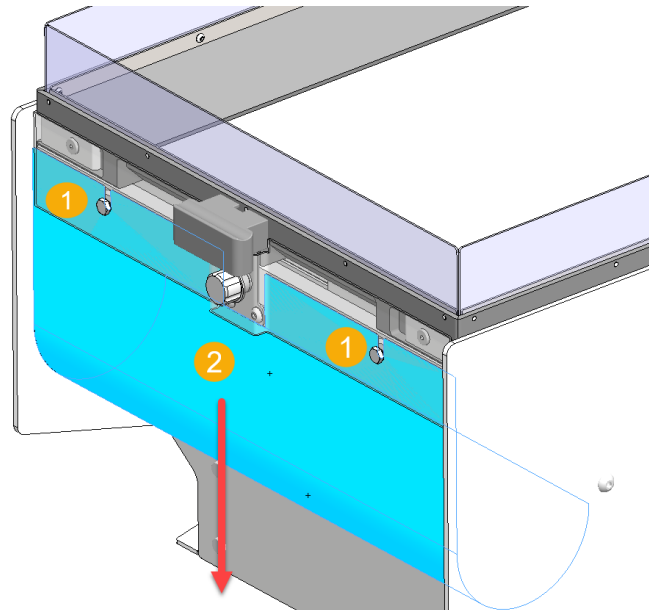

Unlock and pull out the connector plug

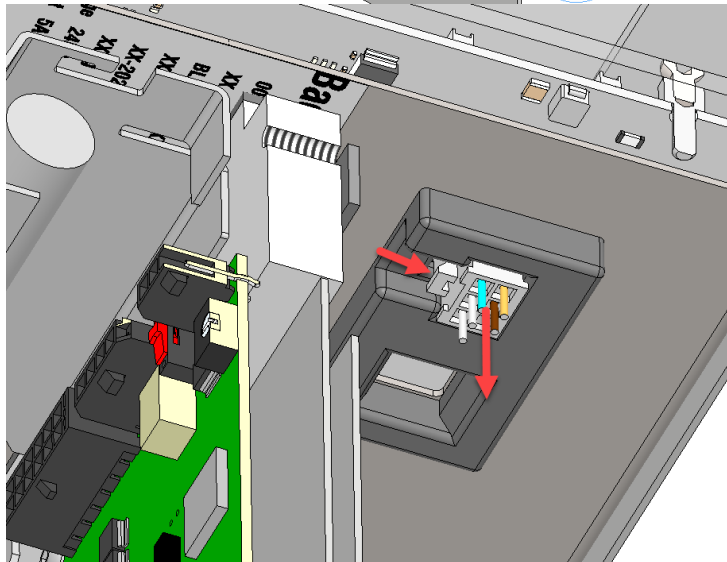
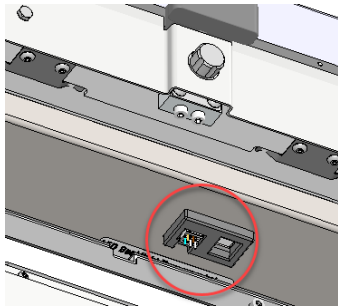

Lift the backlight (1) (magnetically fixed) and pull it forward (2)

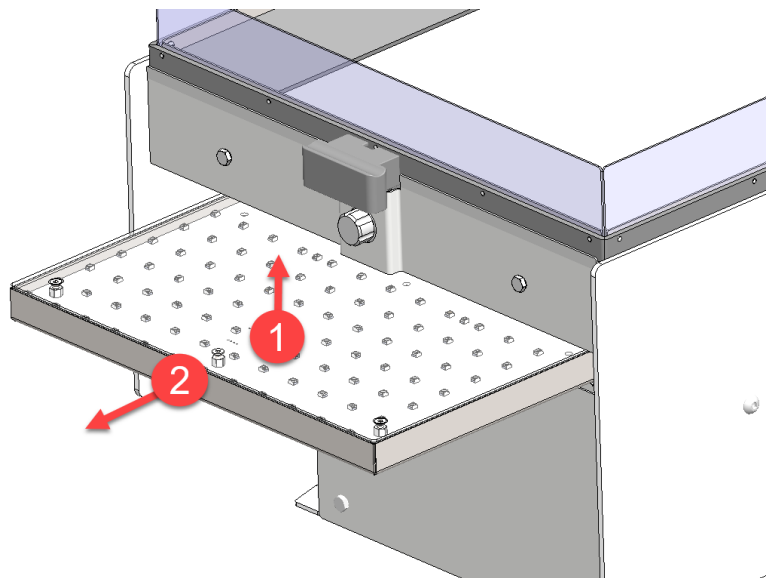

## 4.11 Electrical installation

It is assumed at this point, that the mechanical installation of the feeder components is completed.

<b>DANGER</b>	
	<p><b>Dangers from electrical energy!</b> In case of contact with live parts, damage to the insulation or individual components, there is a risk of death due to electrical current.</p> <ul style="list-style-type: none"> <li>➔ Only qualified electricians may perform work on the electrical system.</li> <li>➔ Before connecting the machine to the power supply, compare the information in the "Technical data" with the data of the power supply system and only connect it if they match.</li> <li>➔ Before starting work on live parts of electrical systems and equipment, make sure they are de-energized and that they remain so for the duration of the work.</li> </ul>

Step		Detail
1	<b>Connect the Flexfeeder to the machine table via grounding bolts and grounding cable</b>	Page 21, Position 19
2	<b>Make sure the power supply is turned off!</b> Install the 24VDC power supply near the machine base. Connecting the 24VDC power cable with flying leads to the power supply or to the designated terminals of your cell controls, including ground earth.	
3	The feeder requires 24VDC/20A power plus a separate external ENABLE signal, <b>which controls the ON/OFF state of the feeder's electrical drives.</b> <ul style="list-style-type: none"> <li>• If 24VDC are applied to the ENABLE input, the drives can be turned ON.</li> <li>• <b>With the ENABLE input pulled to ground, the feeder's drives are turned OFF in safe way.</b></li> </ul>	
4	Connect the flying leads of power cable P/N 007-003-693 (5m) or 007-004-028 (10m) to the 24VDC/20A power supply, including ground earth wire.	Page 30
5	Connect the safety I/O cable 007-005-749 or 007-005-499 to the cell control safety circuits or use the cable and the wire clamp to apply 24V to the Enable-Input. Plug and secure the DSUB 9- connector into the designated receptacle J10 on the feeder interface panel.	Page 30
6	Install the Ethernet patch cable between the feeder and the robot controller.	Page 32
7	Install the Ethernet patch cable between the feeder and the setup PC. If not, setup PC is available at this point, you can test most feeder functions with the touch screen. The patch cable can be installed anytime later.	Page 32
8	Connect camera tower cables with the feeder controls	Page 33
9	Install a secure all covers on the feeder and camera tower.	
10	<b>Switch on the power supply to the cell controller.</b> Be aware, the feeder is factory configured, to automatically initialize all drives when starting up. During initialization, shaker/purge gate, bulk bin/dispenser gate and the locking gate will make slow/small motions.	Chapter 5
11	<b>System tests</b>	Chapter 6

### 4.11.1 Connecting the Feeder to Power, HW Interface for Emergency & Door handling

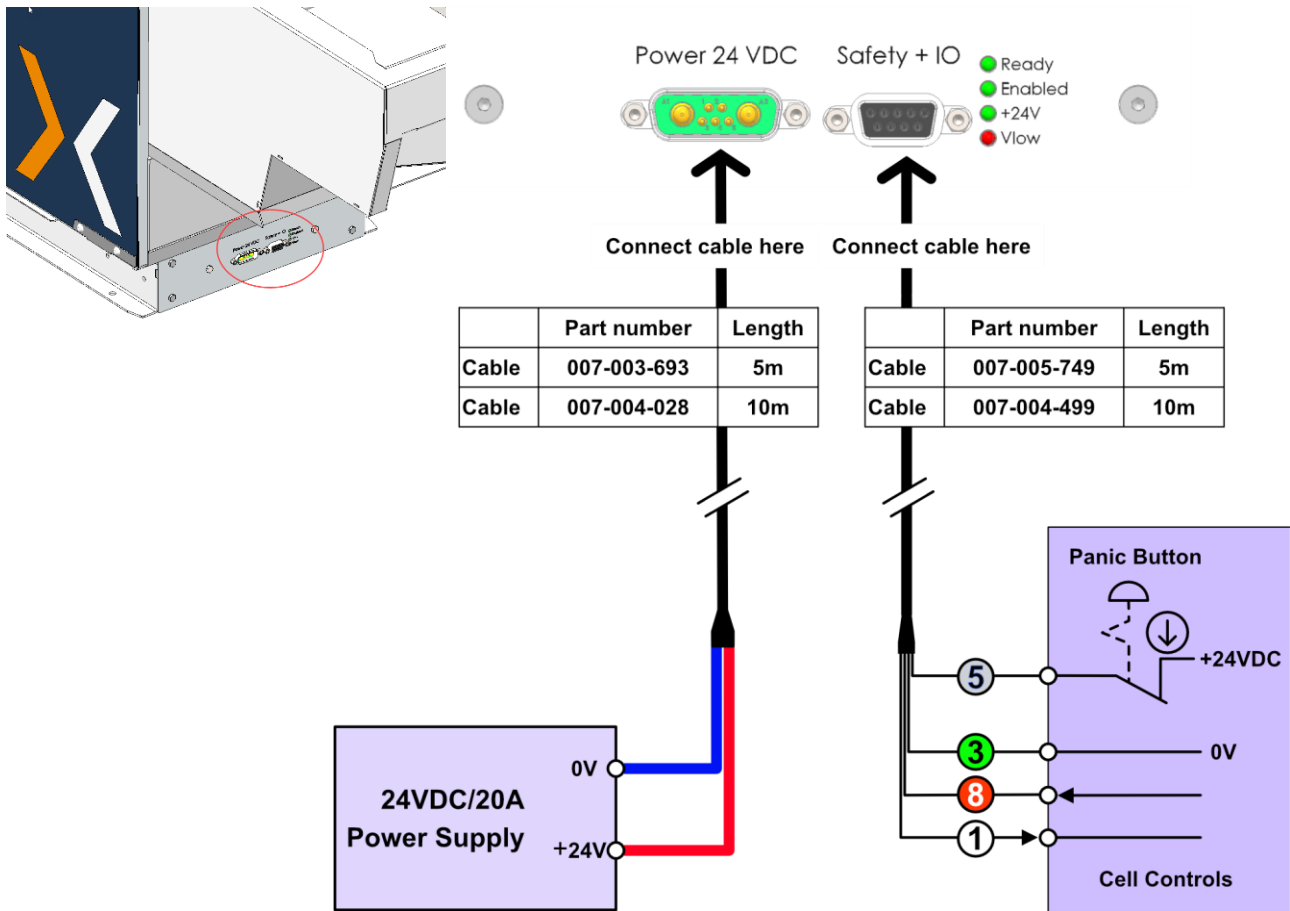

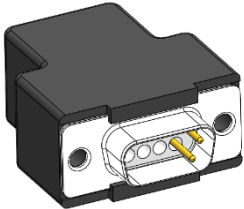
 For test purposes you may use the Enable plug to apply 24V to enable input	DSub9 Pin#	Signal	Feeder	Wire color
	5	Enable	Input	Gray
	3	GND	-	Green
	8	Action stops request controlled by cell	Input	Red
1	All actions stopped controlled by feeder	Output	White	

	<b>WARNING</b>
	<p>Risk of Injury from bypassing the EMERGENCY STOP function</p> <p><b>The Enable plug may only be used by qualified personnel for testing purposes.</b></p> <p>➔ In production operations, the safety I/O cable between PD-J10 and the cell control must be connected correctly.</p>

Plug PD-J3/DSUB2+5 'Power 24VDC' (Pin)		
Pin	Function	Description
A1	24VDC	Power supply
A2	GND	GND

Plug PD-J10/DSUB9 'Safety + I/O' (Socket)			
Pin	Signal	Function	Color code
1	Output	Action Stopped: 24V/ON when feeder reacts to Stop Request 24V/ON stops all movements	white
2	CAN-Bus	CAN_N Data (internally used)	brown
3	GND	Signal-Ground	green
4	Output	Machine Ready: Startup completed, HMI ready, all configured. CAN nodes connected, communication via Ethernet ready.	yellow
5	Input	Enable Power: Must be 24VDC/ON so that the feeder can carry out movements. This signal must be integrated into the system's safety circuit. If this signal drops to 0V, the supply to the power drives is safely switched off.	gray
6	GND	Signal-Ground	violet
7	CAN-Bus	CAN_P Data (used internally)	blue
8	Input	Stop Request: 24VDC, current feeder movements are stopped. Intended for a controlled stop when opening a security door.	red
9	24V out	+24V, 1.5A max.	black

Meaning of the LEDs on the interface panel		
LED	ON	OFF
Ready	Switched like 'Machine ready' (Pin 4 on ' <b>Safety + I/O</b> ' connector)	
Enabled	24VDC is present at pin 5 of the ' <b>Safety+I/O</b> ' connector ( <b>Enable Power</b> )	<b>0V is present at pin 5 of the 'Safety+I/O' connector, thus the drives are off</b>
+24V	24VDC is present between A1 and A2	The feeder is not powered
Vlow	The feeder has detected that the supply voltage is/was too low	The supply voltage is within the tolerance

Power and electrical consumption under typical operating conditions (X185)				
Operating conditions	Electrical power	Feeder	Camera	Backlight
1	36W 1.5A	Switched on	Switched on	Off
2	80W 3A	Share of movements 25%	active	Flashing operation
3	120W 5A	Share of movements 25%	active	Permanent operation
<p><b>IMPORTANT: A 24VDC power supply which delivers 20A continuous current is required to operate the flexfeeder X.</b></p> <p><b>If the Vlow LED on the interface panel lights up RED, this is an indication that the feeder cannot obtain the required electricity.</b></p>				

## 4.11.2 Interfacing Robot, Setup PC, Facility LAN, User Input/Output (UIO)

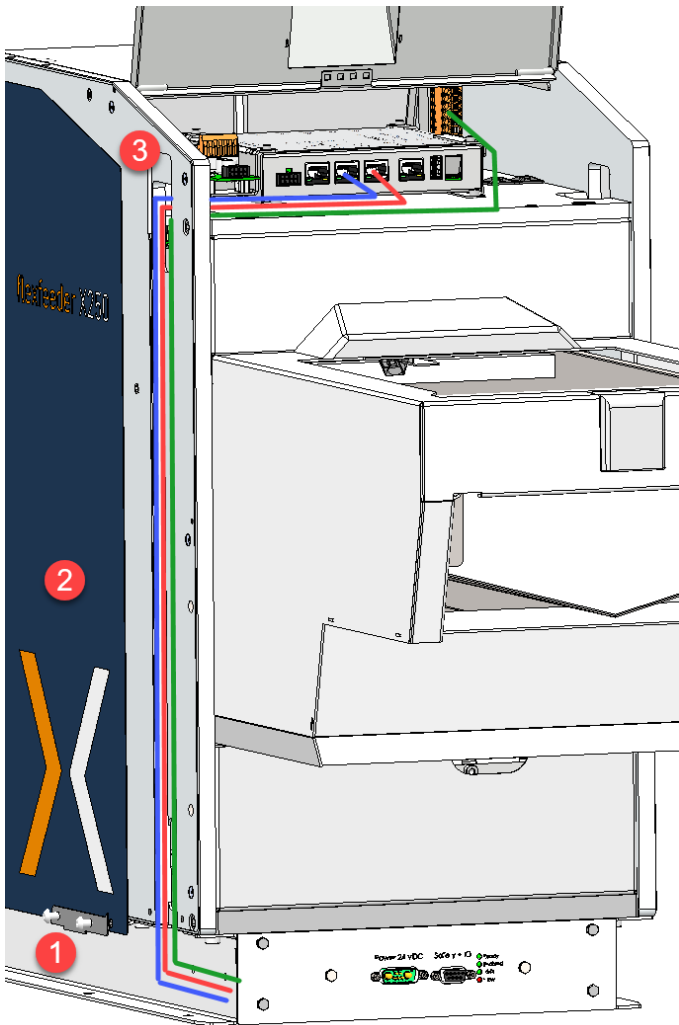

Installation on the user side

1. Remove the locking plate from the side cover.
2. Pull off the side cover (held magnetically)
- 3.

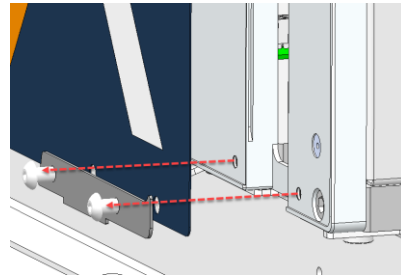

4. Pull out the plastic cover of the cable duct upwards.
5. Lay the cable and connect it to the system controller / UIO according to the diagram.
6. Insert the plastic cover into the side grooves from above and push it downwards.
7. Insert side cover and secure with locking plate.

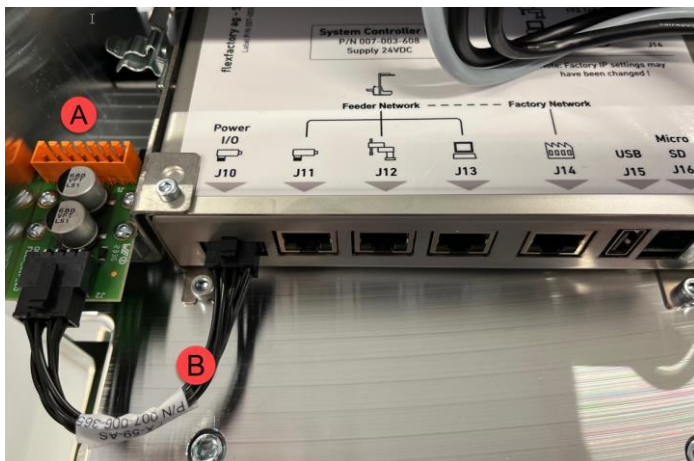

Connections on the system controller

J10 Camera Power I/O

A: Camera Interface Print (CIP)

B: Cable CID 59: 007-006-365

J11 Ethernet Camera

J12 Ethernet to Robot (blue)

J13 Ethernet to PC (red)

J14 LAN

J15 USB

J16 Micro SD

User Input/Output UIO (green)

Port SC	CID	Cable P/N	Label	Function	Incl. in delivery
J10	59	007-006-365	FX-59-AS, SC-J10 to CIP-J2	Camera Power I/O (24V Trigger)	yes
J11	56	007-001-097	FX-56-BH, SC-J11	Ethernet to Camera	yes
J12	EN3	007-002-472		Ethernet to Robot	
J13	EN2	007-002-472		Ethernet to Setup-PC	yes
J14	EN1	007-002-472		LAN (Remote access)	

### 4.11.3 Connecting camera tower cables with the feeder controls

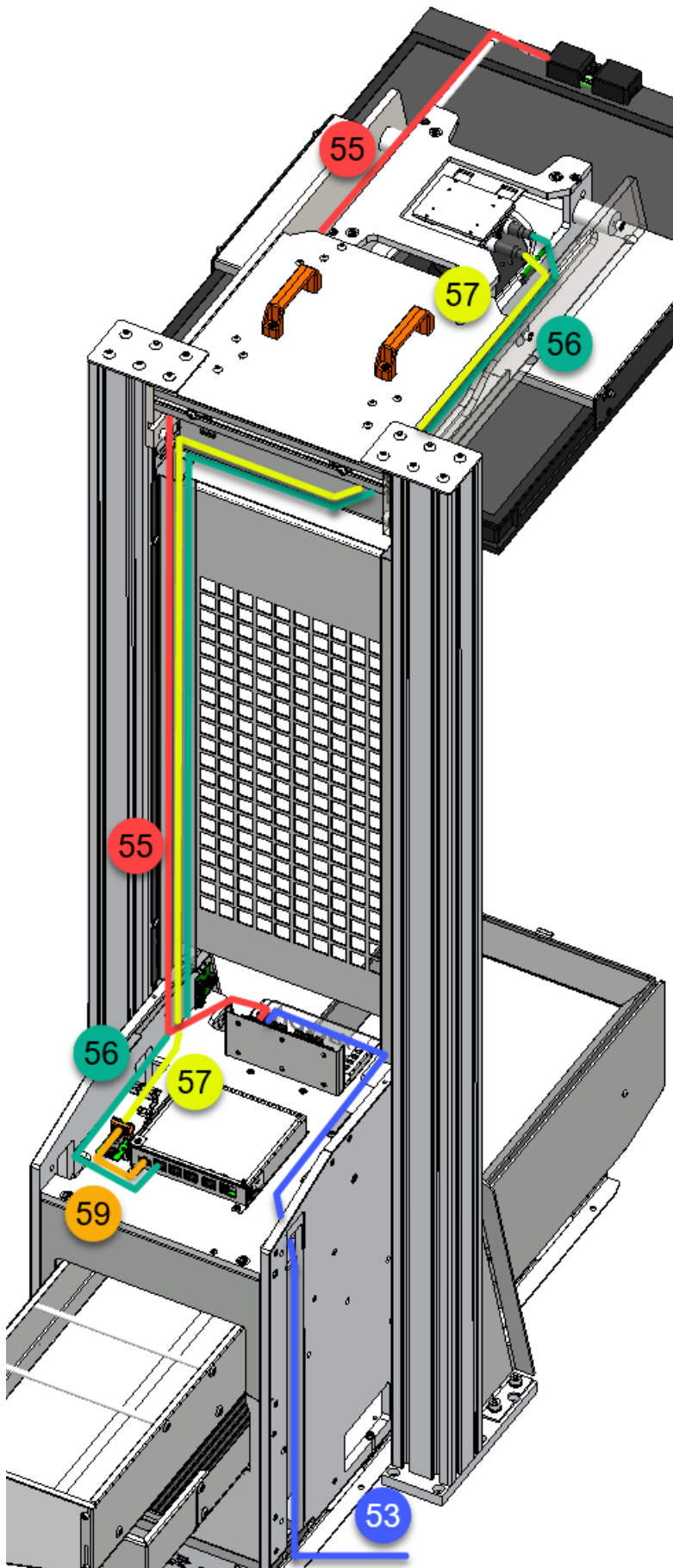

Numbering according to CID (Cable Identification No.)

See control diagram 4.12

Before laying the cables, take away the cover plates marked yellow.

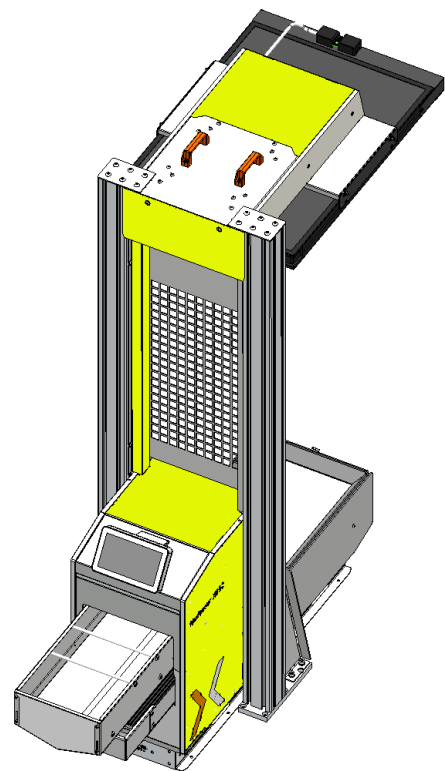

## 4.12 Control diagram 007-006-627E

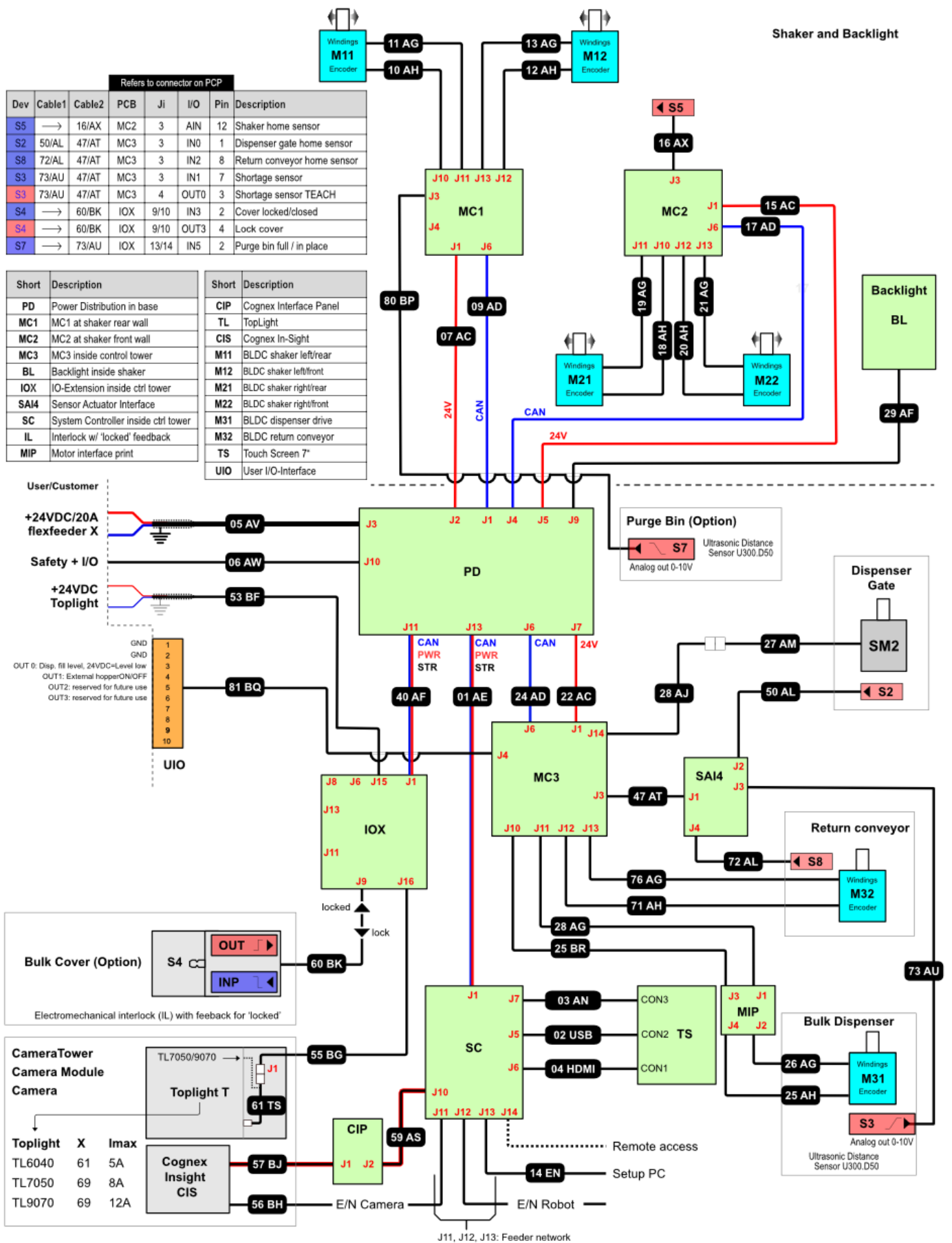

## 4.13 Preparation of system operating instructions / Safety concept

	INFORMATION
	<p>The flexfeeder is subject to the higher-level system or cell control and must be integrated by the operator into his safety concept and risk analysis.</p> <p>The operator is responsible for integrating the machine into the overarching safety concept, as does its documentation in a machine or system operating manual.</p>

Further information required to create the system operating instructions for the flexfeeder can be requested from Flexfactory AG.

## 5 Establish network connection

In this chapter it is described how to establish a network connection to the Flexfeeder.

### 5.1 Network connectors

The following image shows the network connectors (RJ45) at the flexfeeder system controller:

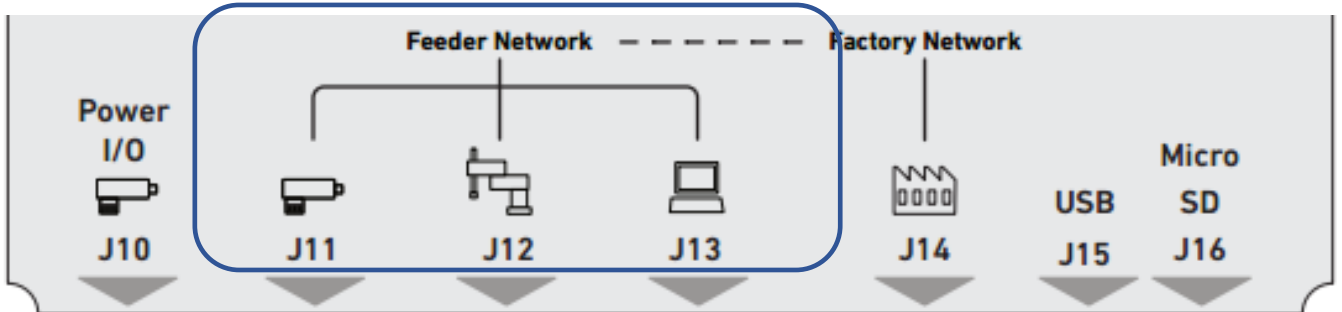

J11...J13 Feeder Network (3-port switch for the connection of camera, robot/PLC and setup PC)

J14 Factory Network (connection to integrate the feeder into a company network)

### 5.2 IP-addresses

The system is delivered with the following fixed IP addresses:

- Flexfeeder 192.168.2.100 (Subnet Mask 255.255.255.0)
- Cognex camera 192.168.2.10 (Subnet Mask 255.255.255.0)
- Factory network (J14) DHCP

So, set the IP address for your computer's LAN connection to 192.168.2.x (where x is not 10 nor 100 and less than 254).

## 6 System tests

To ensure that the Flexfeeder has been wired correctly and is functioning, perform the following tests:

### 6.1 Initialize the Feeder

Switch on the power supply to the Flexfeeder and wait until the Flexfeeder has completely booted up. As soon as the Flexfeeder is ready, you'll see the text "Please execute a Reset/Homing" in the status bar. Then carry out a homing by pressing the orange flashing Reset button.

The feeder now starts its reference motion. As soon as the Flexfeeder is successfully initialized, the Feeder is in Setup mode (= manual mode):

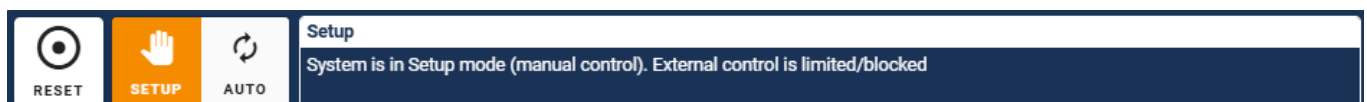

## 6.2 Test the lighting

To ensure that the lighting is working correctly, you can test it via the “Operations” menu by switching the backlight or the Toplight on and off. Please note that the light of the infrared version backlight is not visible to the human eye. However, the infrared backlight features 4 blue indicator-LEDs on the illuminated field that light up simultaneously with the infrared light.

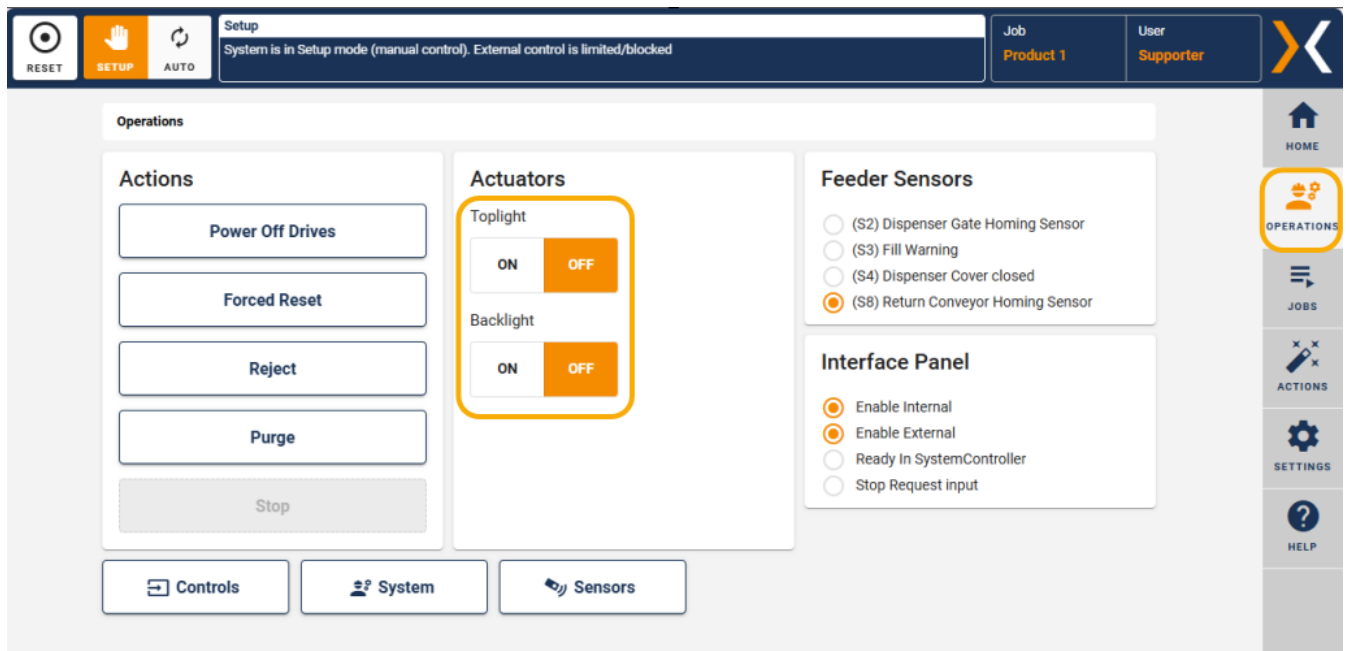

## 6.3 Test feeder actions

Under the “Actions” tab on the right side of the control panel, you find the different motion pattern of the Flexfeeder. After pressing the button for a specific motion once, the corresponding parameters are displayed, which you can adjust if required. By pressing the selected button again, the feeder motion can be executed.

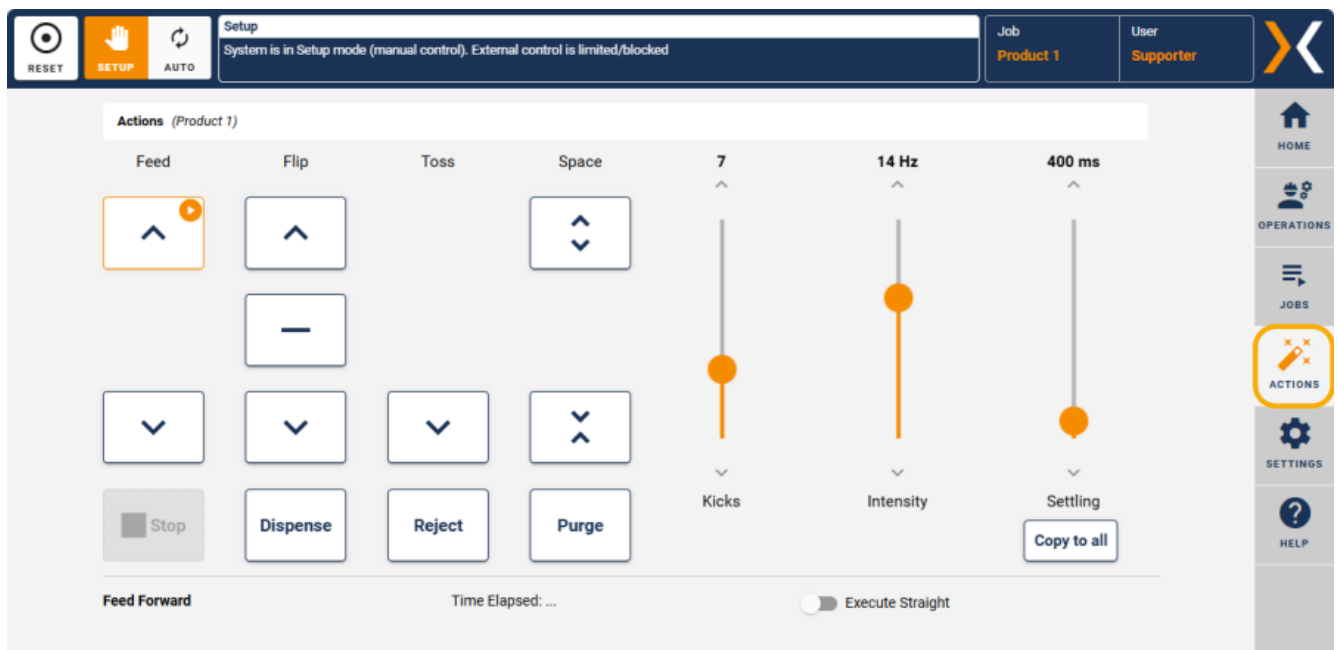

## 7 Technical data

### 7.1 Dimensions, weight and capacity

Description	XQ185	XQ250	XQ350	Units
Dimension WxHxL	254 x 636 x 1187	319 x 676 x 1350	419 x 716 x 1476	mm
Vertical height bulk outlet	35	75	90	mm
Illuminated area Backlight	185 x 310	250 x 370	350 x 495	mm
Workspace	185 x 247	250 x 330	350 x 467	mm
Hight level workspace	228.5	226.7	224.8	mm
Border Workspace**	35 (70)	35 (70)	35 (70)	mm
Vertical height return channel***	40	50	80	mm
Weight Feeder	54	67	82	Kg
Max. weight **** Camera tower without Damping unit	30	45	47	Kg
Noise level	<70	<70	<70	dB(A)
Bulk capacity*	8 / 10	12.5 / 15	21.5 / 18	dm <sup>3</sup> / Kg
Max. Load on workspace*	1000	1500	2000	g
*Guide value, **Without (with) skip protection, ***max. Part height that enables return ****Weight tower version 5MP, version 2MP the weight is reduced by 2 kg				

See the dimensional drawings and CAD data on the Flexfactory AG homepage:

<https://www.flexfactory.com/>

### 7.2 Electrical supply data

Description	XQ185	XQ250	XQ350	Units
Power and electrical consumption	24/20	24/20	24/20	VDC/A
Power and electrical consumption Toplight	24/6	24/8	24/15	VDC/A
Compressed air	no	no	no	

### 7.3 Operating conditions

Description	XQ185	XQ250	XQ350	Units
Room temperature	17 - 35	17 - 35	17 - 35	°C

## 7.4 Parts requirements for the bulk material

Description	XQ185	XQ250	XQ350	Units
Requirement for the parts	dry, clean, (not greasy) 5 – 45°C			
Max dimension*	60	85	120	mm
Min. part height	0.2	0.2	0.2	mm
Max. Weight	60	80	100	g
Part geometry	any			
Material	Metals, glass, plastics, elastomers, wood			
*Guideline	See also: Vertical height bulk outlet			

## 7.5 Emissions

Noise emissions:

The noise emissions from the feeder without bulk material are below 70dB(A). A measurement of noise emissions from the parts to be processed must be made in the final operating environment. Noise emissions can vary greatly depending on the material being conveyed. In this regard, the noise protection measures on the higher-level machine must be adapted to the operator's regulations. The bunker, which normally stands outside the protective casing, is equipped with a noise insulation mat.

Vibrations:

If the feeders are properly installed on a metal tabletop (see Chapter 4.7), no dangerous vibrations or oscillations will occur.

## 8 Maintenance

### 8.1 Information

<b>i</b>	INFORMATION
	<p>During all maintenance work, the safety instructions in the operating manual of the main control system must be followed.</p> <p>The intervals for maintenance procedures vary depending on the system, operating environment, and usage intensity. If contaminated parts or bulk materials with deposits are introduced, it may be necessary to shorten the maintenance intervals to ensure optimal device performance.</p> <p>➔ Upon request, flexfactory AG will compile a system-specific spare parts package.</p>

### 8.2 Periodic maintenance work

Maintenance work	Description	Interval
Clean device	Clean the feed plate, bulk container, and return trough with a vacuum cleaner.	daily or as needed
Clean feed plate	Remove the feed plate (see 4.9) and clean it with a non-abrasive cleaning agent, such as cleaning alcohol. Contamination can affect image processing, especially when using a backlight.	weekly
Clean and check Backlight	Remove the feed plate and the plexiglass plate underneath (see 4.9). Clean the glass cover of the backlight with a glass cleaner to remove dust. Contamination of the glass cover can affect image processing. Perform a functional check of the backlight and inspect the LEDs.	quarterly
Mechanical control - Shaker drive module - Bulk drive	Check the timing belts for wear and inspect the bearing points (refer to service videos). This maintenance can also be carried out by a service technician from flexfactory AG	yearly

# 9 Appendix

## 9.1 Declaration of Incorporation

# Declaration of Incorporation

In accordance with EC Machinery Directive

2006/42/EG, Anhang II B

Manufacturer: Flexfactory AG  
Giessenstrasse 15 +41 44 774 55 66  
CH-Dietikon [info@flexfactory.com](mailto:info@flexfactory.com)

We hereby declare that the product named below, based on its design, conception, and construction, in the version placed on the market by us, complies with the essential safety requirements of the Machinery Directive, including the amendments applicable at the time of the declaration, up to the interfaces described in the attached technical documentation. The essential safety requirements have been complied with in accordance with the appendix to this declaration of incorporation.

Product: **flexfeeder** – flexible part feeding system

Machine models: **XQ185, XQ250, XQ350**

Serial-No:

EC Directives	Machinery Directive	2006/42/EG
	Electromagnetic Compatibility (EMC) Directive	2014/30/EU
	Low Voltage Directive	2014/35/EU
Applied harmonised standards	Safety of Machinery	EN ISO 12100:2010
	Safety of machinery - Safety distances to prevent hazard zones being reached by upper and lower limbs	EN ISO 13857:2020
	Electromagnetic compatibility (EMC) Part 6-2: Generic standards - Immunity standard for industrial environments	EN 61000-6-2:2019
	Electromagnetic compatibility (EMC) Part 6-4 Generic standards - Emission	EN 61000-6-4:2019

The manufacturer undertakes to submit the documentation electronically to the competent national authority upon reasoned request. The specific technical documentation for the machinery in accordance with Annex VII, Part B has been prepared. Authorized representative for compiling the technical documentation:

Peter Ulrich, Giessenstrasse 15, 8953 Dietikon, Switzerland

The flexfeeders are intended for integration into complete production systems. Their commissioning is prohibited until it has been ensured that the entire machinery into which the mentioned partly completed machinery is installed complies with the provisions of the Machinery Directive.

Dietikon, Schweiz, den 12.6.2025

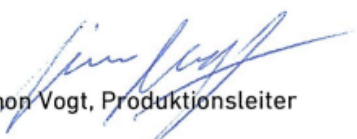
  
Simon Vogt, Produktionsleiter

This declaration does not contain any guarantees. The safety instructions in the product documentation must be observed. Any modification to the listed products without the manufacturer's consent will render this declaration invalid.

## 9.2 Dimension drawing: Base plate mounting pattern

Flexfeeder XQ185

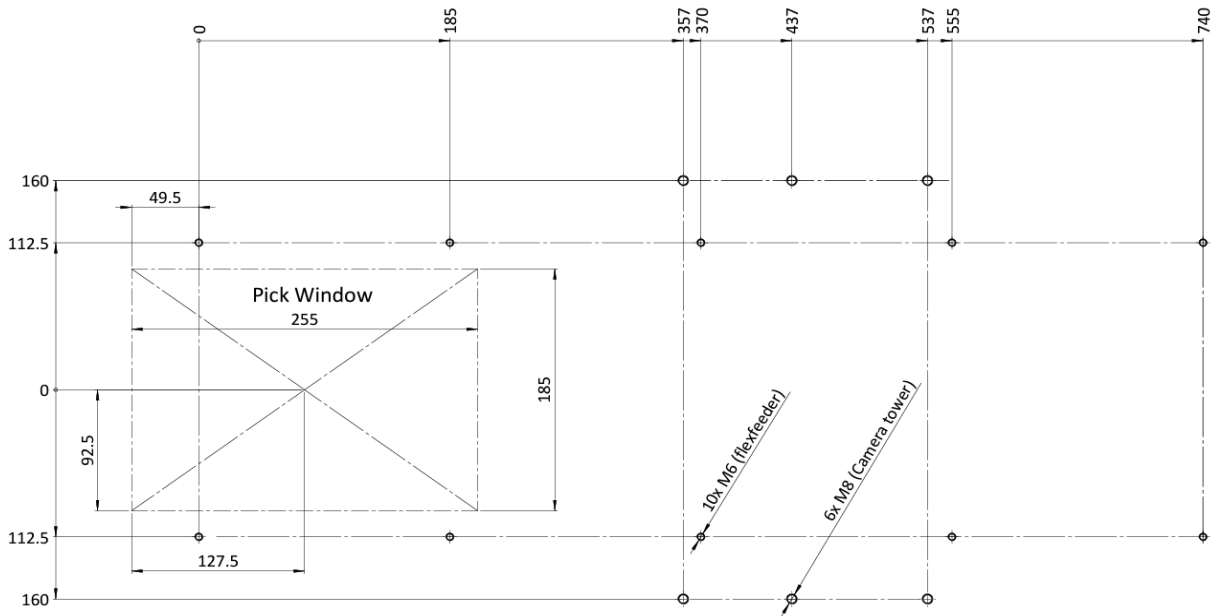

Flexfeeder XQ250

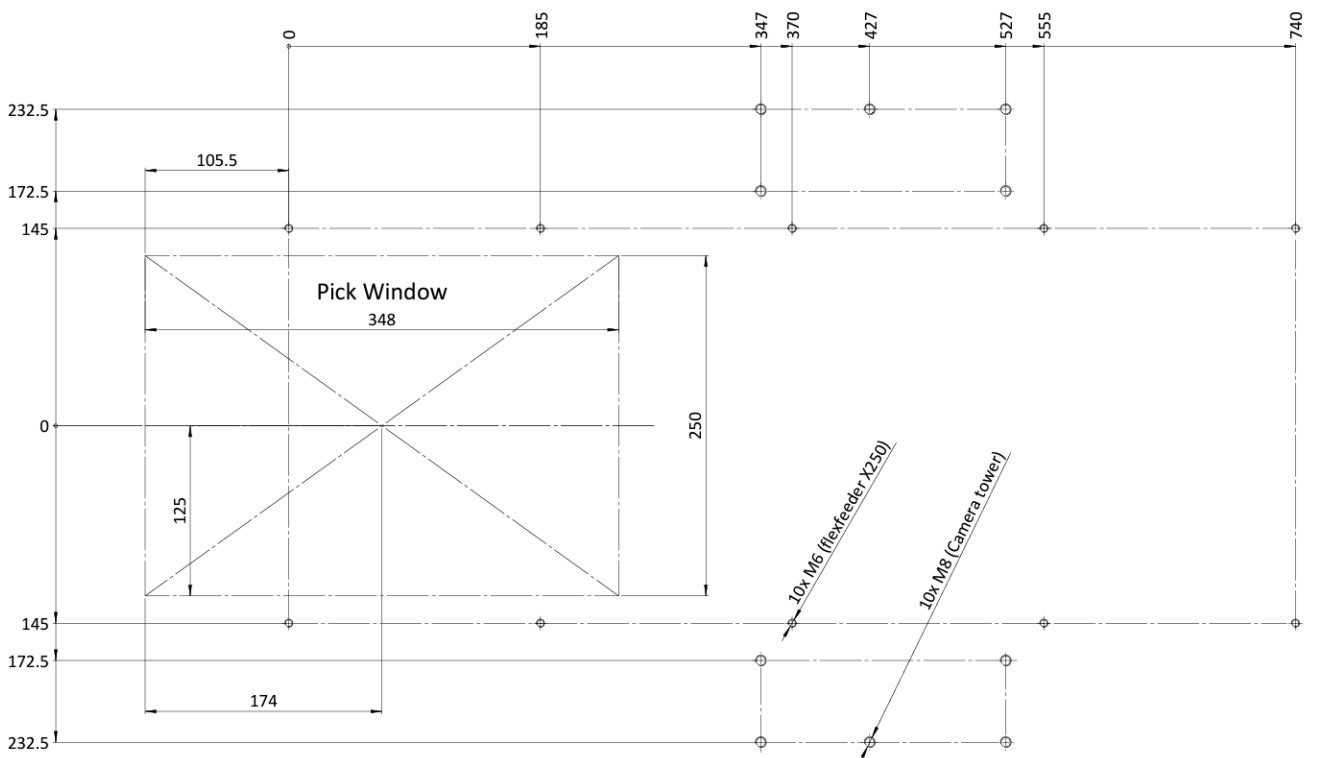

# Flexfeeder XQ350

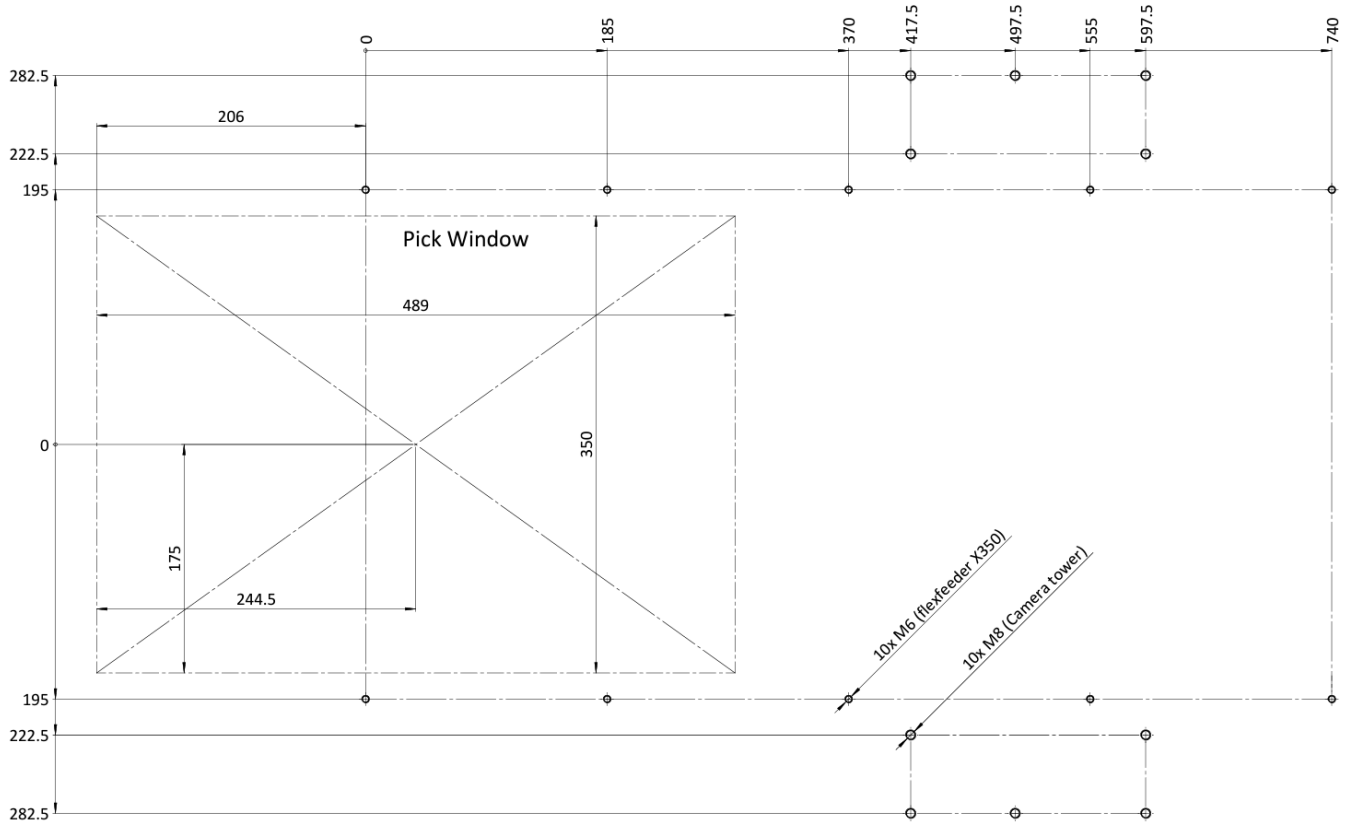

## 9.3 Dimension drawing

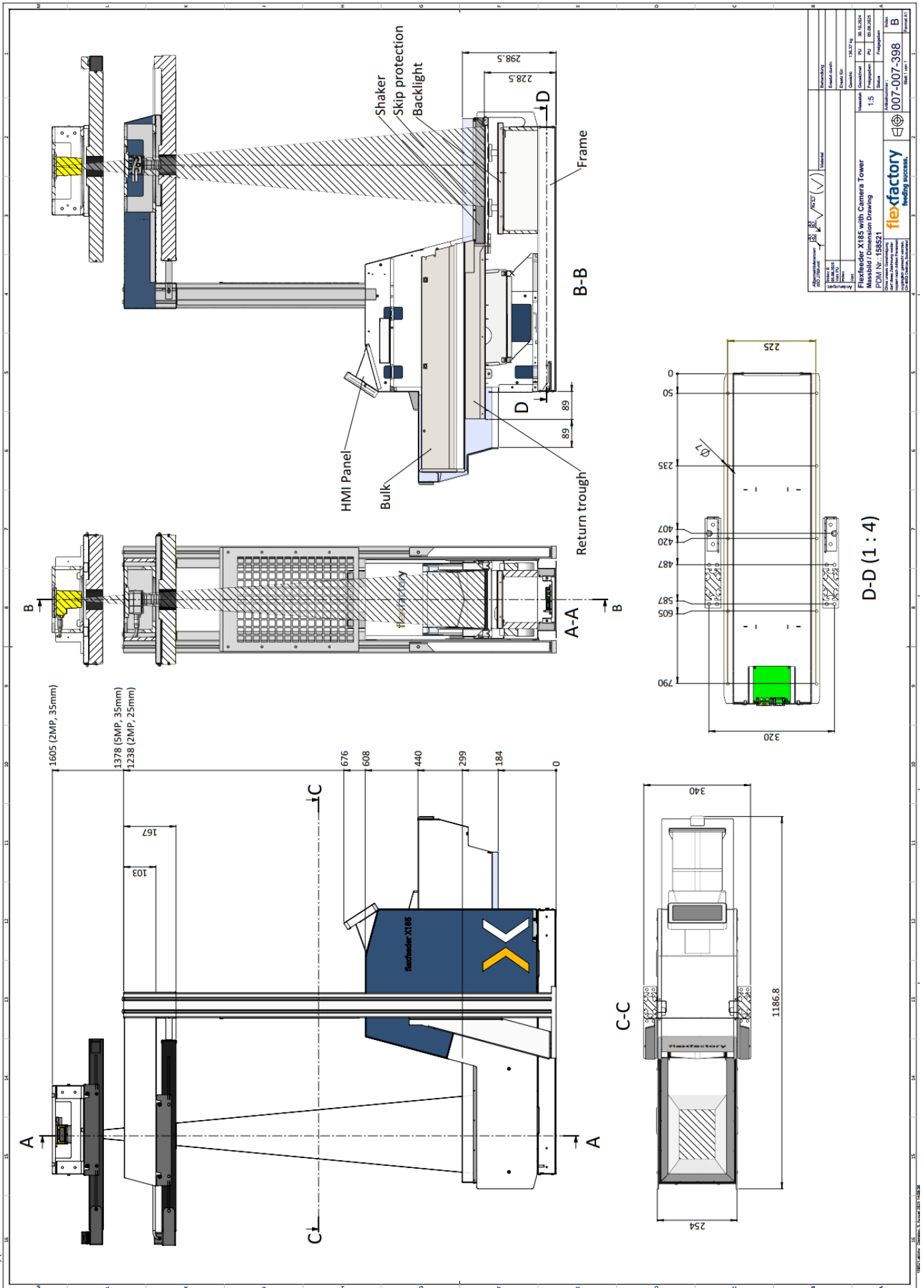

Approved by:                  Date: 15.02.2024	Drawn by:                  Date: 08.08.2023
Checked by:                  Date: 08.08.2023	PDM No.: 188521
Project: flexfactory X185 with Camera Tower Messing / Dimension Drawing	Scale: 1:5 Status: Preparation
flexfactory feeding success.	007-007-398 B

D-D (1 : 4)



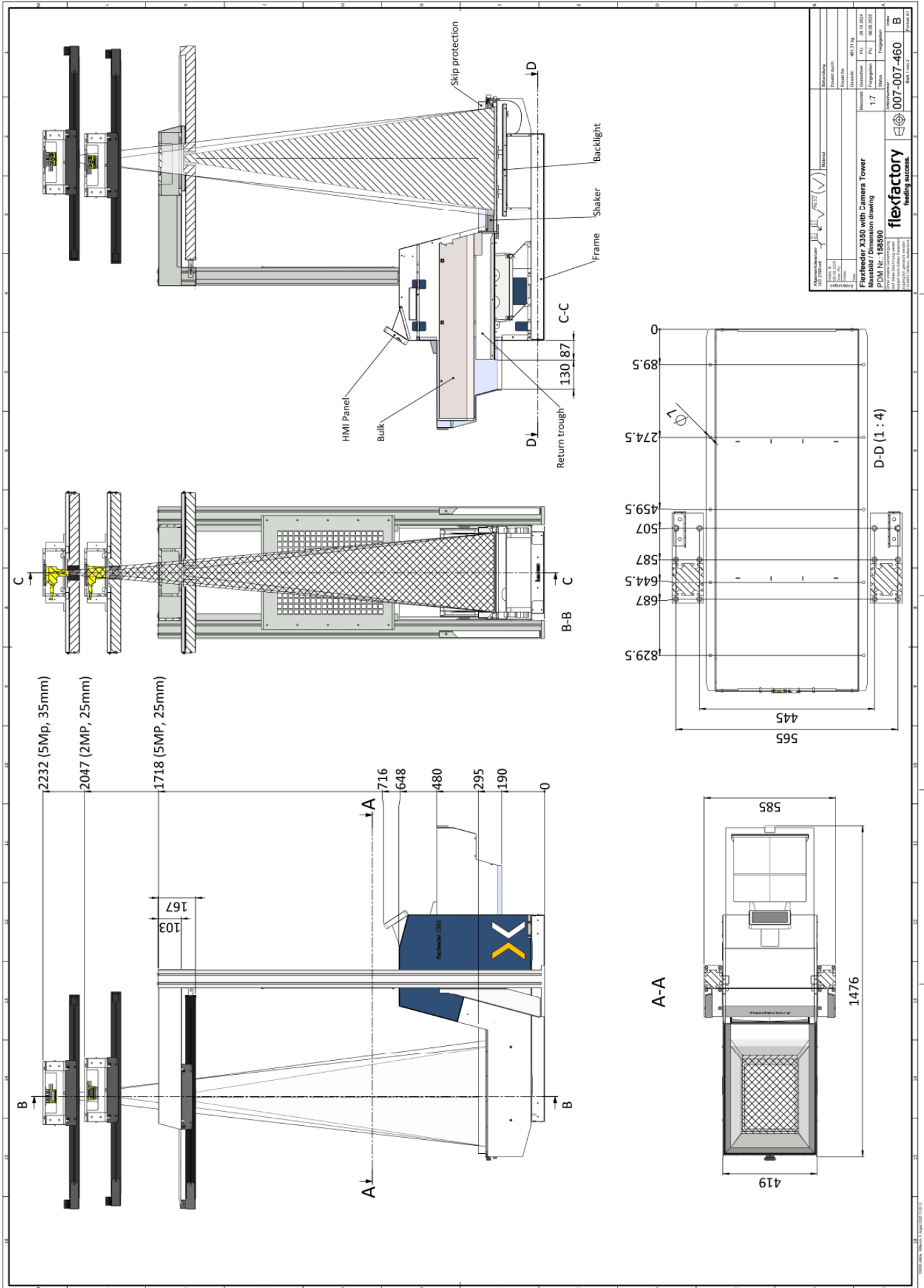

## 9.4 Camera mounting distance (Cognex)

Camera model: In-Sight 7802 (2MP)							
Resolution	1200	1600					
flexfeeder	W [mm]	L [mm]	Lens f	A [mm]	B [mm]	C [mm]	A : W
XQ 185	185	256	25mm	995	1224	229	5.4
			35mm	1365	1594		7.4
XQ 250	250	346	25mm	1330	1557	227	5.3
			35mm	1835	2062		7.3
XQ 350	350	484	16mm	1180	1405	225	3.4
			25mm	1810	2035		5.2

Camera model: In-Sight 7905 (5MP)							
Resolution	2048	2448					
flexfeeder	W [mm]	L [mm]	Lens f	A [mm]	B [mm]	C [mm]	A : W
XQ 185	185	243	25mm	840	1069	229	4.5
			35mm	1135	1364		6.1
XQ 250	250	326	25mm	1080	1307	227	4.3
			35mm	1480	1707		5.9
XQ 350	350	457	25mm	1480	1705	225	4.2
			35mm	1995	2220		5.7

