

flexfeeder XQ

Step-by-Step Guide flexfeeder-Installation

flexfactory ag
Giessenstrasse 15
CH-8953 Dietikon
Phone +41 44 774 55 66
Fax +41 44 774 55 67
info@flexfactory.com
flexfactory.com



Table of contents

1	Hardware installation	3
2	Electrical installation	4
2.1	Connection overview	4
2.2	Ground connection.....	5
2.3	Power supply	5
2.4	Safety I/O	5
2.5	Wiring the camera and the optional toplight.....	6
3	Establish network connection	7
3.1	Network connectors	7
3.2	IP-addresses.....	7
4	System tests	7
4.1	Initialize the Feeder	7
4.2	Test the lighting.....	8
4.3	Test feeder actions.....	8
5	Additional information	8

1 Hardware installation

The Flexfeeder is attached to the machine table with at least four M6 screws according to the mounting diagram i.e. the dimension drawing.

The camera tower with toplight is available as an option and is not included in the standard setup.

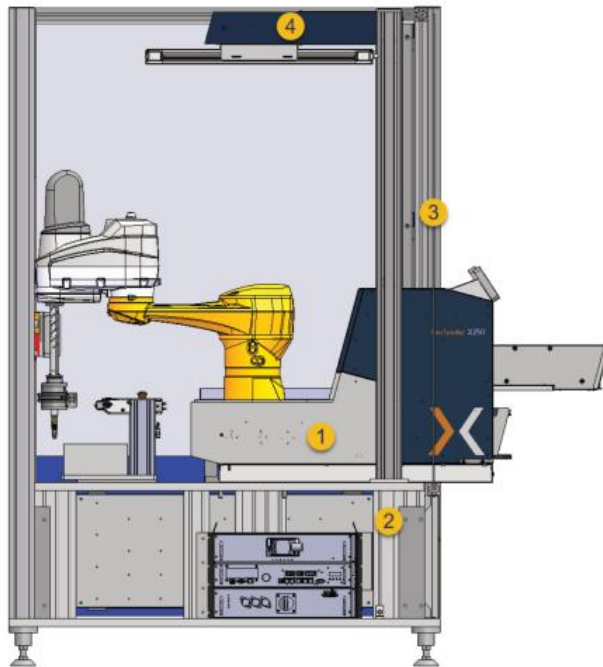

Position	Baugruppe
1	Flexfeeder
2	Maschinentisch
3	Zellenschutzeinrichtung
4	Option: Kameraturm mit Toplight

Depending on the size of the Flexfeeder and the camera resolution, there are different camera mounting distances. The documents under the following links can be used to determine the correct camera distance for your application:

2.0MP Vision System:

[Mounting-distances_is7802_flexfeeder.pdf](#)

5.0MP Vision System:

[Mounting-distances_is7905_flexfeeder.pdf](#)

Please also note the alignment of the camera to the flexfeeder. The camera cables run to the side of the Flexfeeder, according to the illustration in the mounting distance document.

2 Electrical installation

2.1 Connection overview

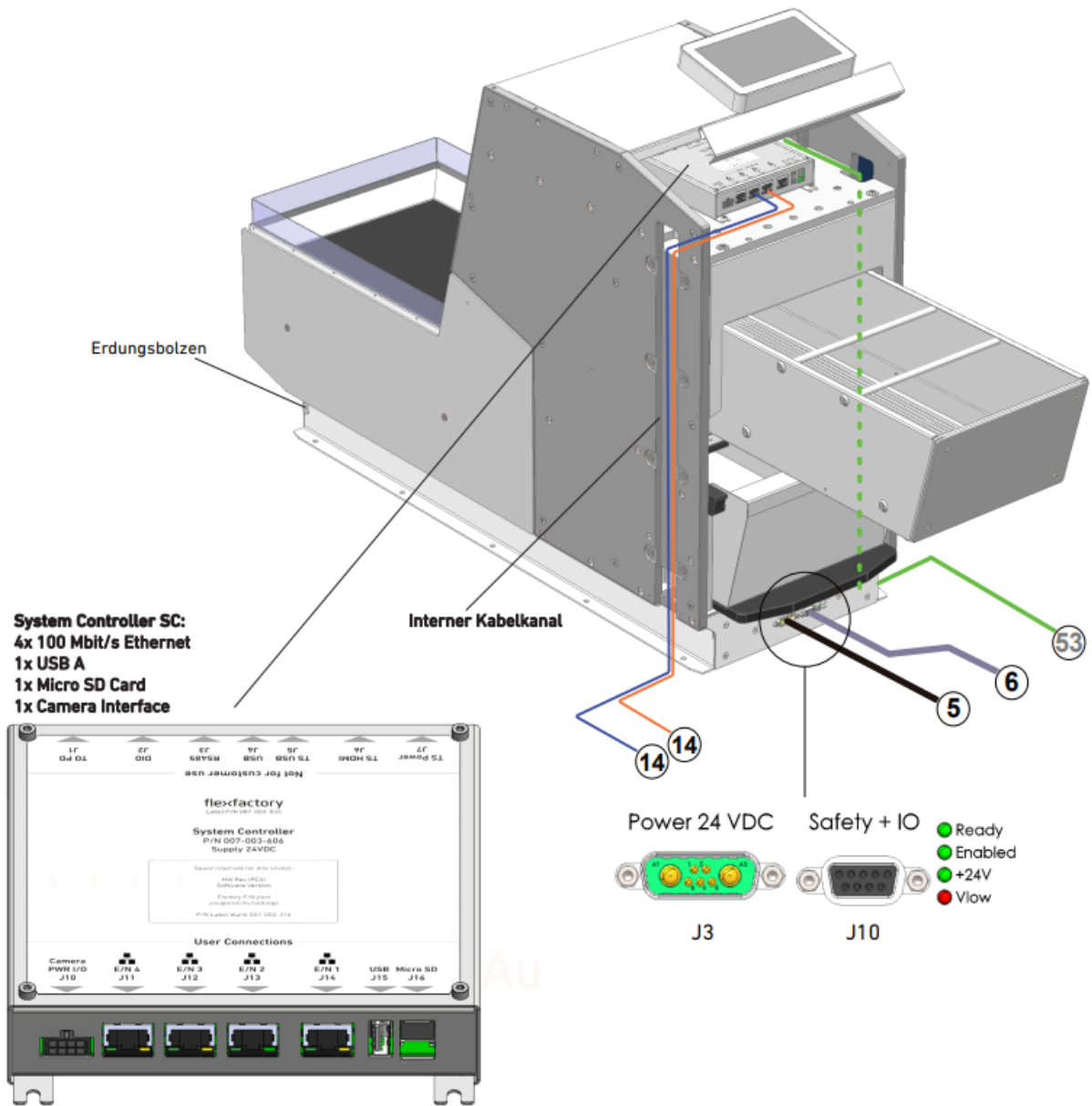

Externe elektrische Anschlusskabel					
Kabel-Nr.*	Kennzeichnung	Art-Nr.	Funktion und Details	Länge	Lieferumfang
5	Cable, FX-05-AV PD-J3 -> 24VDC Supply	007-003-693	24VDC Stromversorgung Feeder Feederseitig: DSUB Power (Buchsen) Steuerungsseite: Litzen 2x2,5mm ² + Schirm	5m	ja
6	Cable, FX-06-AW PD-J10 -> Ext. Controls	007-004-499	Sicherheitskreis, Digitale I/O, CAN Feederseitig: DSUB9 (Stifte) Steuerungsseite: Litzen 9x0.25mm ² Farbcode der Litzen siehe Seite 29	5m	ja
14	Cable, FX-14-Patch Switch -> Robot	007-002-472	100 Mbit/s Ethernet Feeder-Roboter Cat 6, RJ45 auf RJ45	5m	nein
53	Cable, FX-53 EX24V -> IOX-J15 (Toplight)	007-005-353	24VDC Stromversorgung Toplight Steuerungsseite: Litzen 2x1,5mm ² + Schirm	5.1 m	ja

2.2 Ground connection

You should connect the Flexfeeder to the machine table using the earthing bolt provided on the substructure with a grounding cable (see figure above for the grounding bolt).

2.3 Power supply

The Flexfeeder has to be powered by the connector J3 with 24VDC / 20A.

2.4 Safety I/O

In order for the drive power of the Flexfeeder to be switched on, a digital release signal ("Enable") is required, which is typically provided by a safety circuit. For the test phase, the Enable signal can be permanently applied to J10 by using the supplied jumper plug.

Additional information you find in the document "flexfeeder Safety+IO interface" under the following link: [Safety-and-IO-interface.pdf](#)

2.5 Wiring the camera and the optional toplight

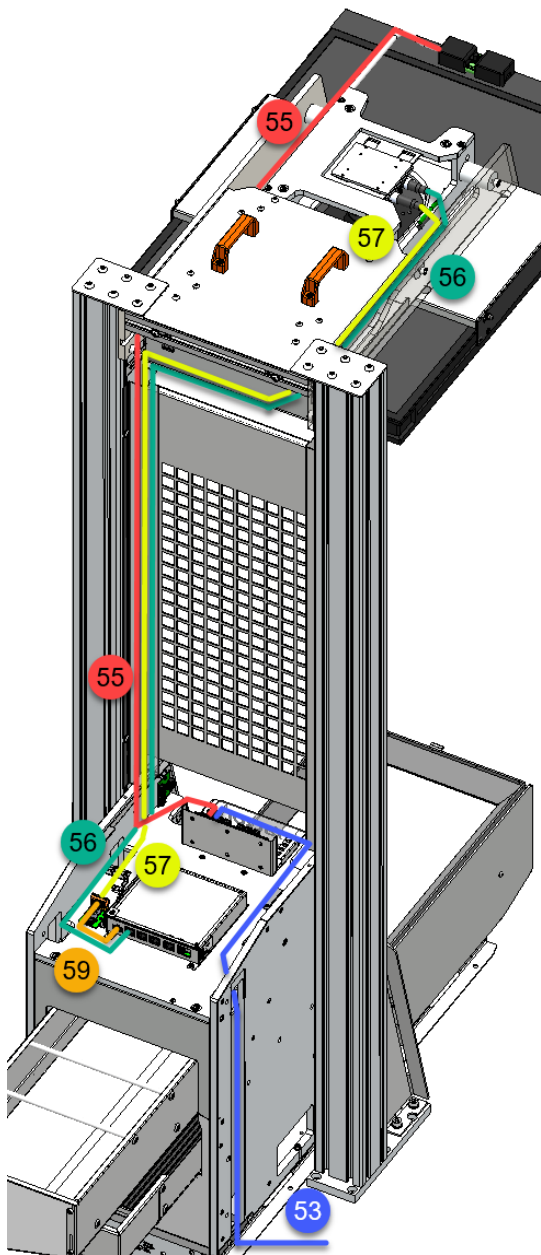

Before installing the cables, remove the yellow marked covers

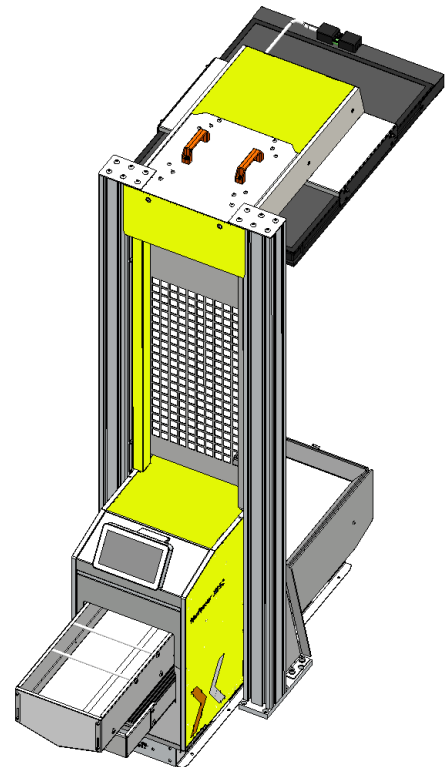

Cable-no. / Color	Connection Flexfeeder	Connection external	Function	Remark
53 – blue	I/O-Board – J15	24V supply	Toplight Power	optional
55 – red	I/O-Board – J16	Toplight	Toplight Pwr/Ctrl	optional
56 – green	System controller (SC) – J11	Cognex-camera	Ethernet cable	
57 – yellow	Cognex Interface Print (CIS) – J1	Cognex-camera	Power/IO cable	
59 - orange	SC – J10 / CIS – J2	-	Power/IO cable	

Additional information about the wiring you find in the System-diagram under the following link:
[Systemdiagram flexfeeder XQ.pdf](#)

3 Establish network connection

In this chapter it is described how to establish a network connection to the Flexfeeder.

3.1 Network connectors

The following image shows the network connectors (RJ45) at the flexfeeder system controller:

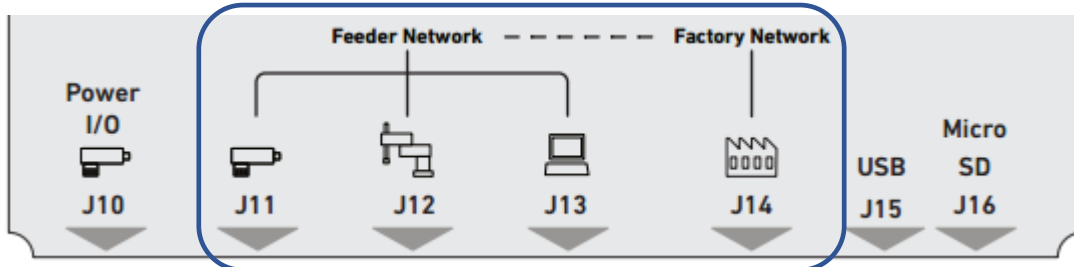

J11...J13 Feeder Network (3-port switch for the connection of camera, robot/PLC and setup PC)

J14 Factory Network (connection to integrate the feeder into a company network)

3.2 IP-addresses

The system is delivered with the following fixed IP addresses:

- Flexfeeder 192.168.2.100 (Subnet Mask 255.255.255.0)
- Cognex camera 192.168.2.10 (Subnet Mask 255.255.255.0)
- Factory network (J14) DHCP

So, set the IP address for your computer's LAN connection to 192.168.2.x (where x is not 10 nor 100 and less than 254).

4 System tests

To ensure that the Flexfeeder has been wired correctly and is functioning, perform the following tests:

4.1 Initialize the Feeder

Switch on the power supply to the Flexfeeder and wait until the Flexfeeder has completely booted up. As soon as the Flexfeeder is ready, you'll see the text "Please execute a Reset/Homing" in the status bar. Then carry out a homing by pressing the orange flashing Reset button.

The feeder now starts its reference motion. As soon as the Flexfeeder is successfully initialized, the Feeder is in Setup mode (= manual mode):

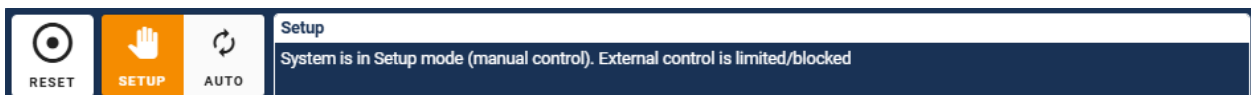

4.2 Test the lighting

To ensure that the lighting is working correctly, you can test it via the “Operations” menu by switching the backlight or the toplight on and off. Please note that the light of the infrared version backlight is not visible to the human eye. However, the infrared backlight features 4 blue indicator-LEDs on the illuminated field that light up simultaneously with the infrared light.

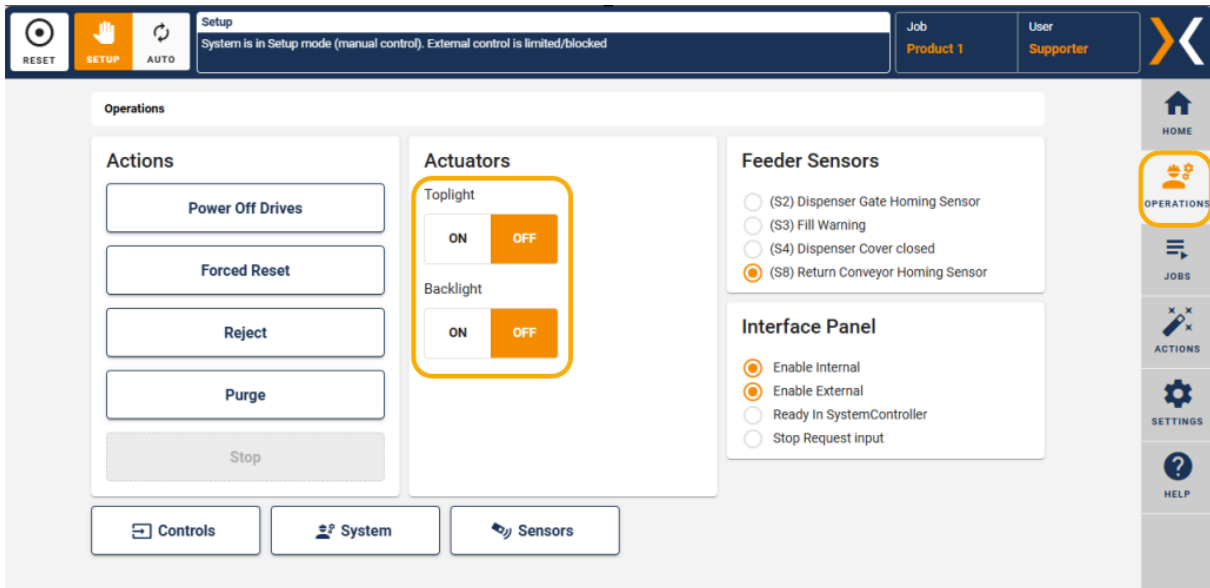

4.3 Test feeder actions

Under the “Actions” tab on the right side of the control panel, you find the different motion pattern of the Flexfeeder. After pressing the button for a specific motion once, the corresponding parameters are displayed, which you can adjust if required. By pressing the selected button again, the feeder motion can be executed.

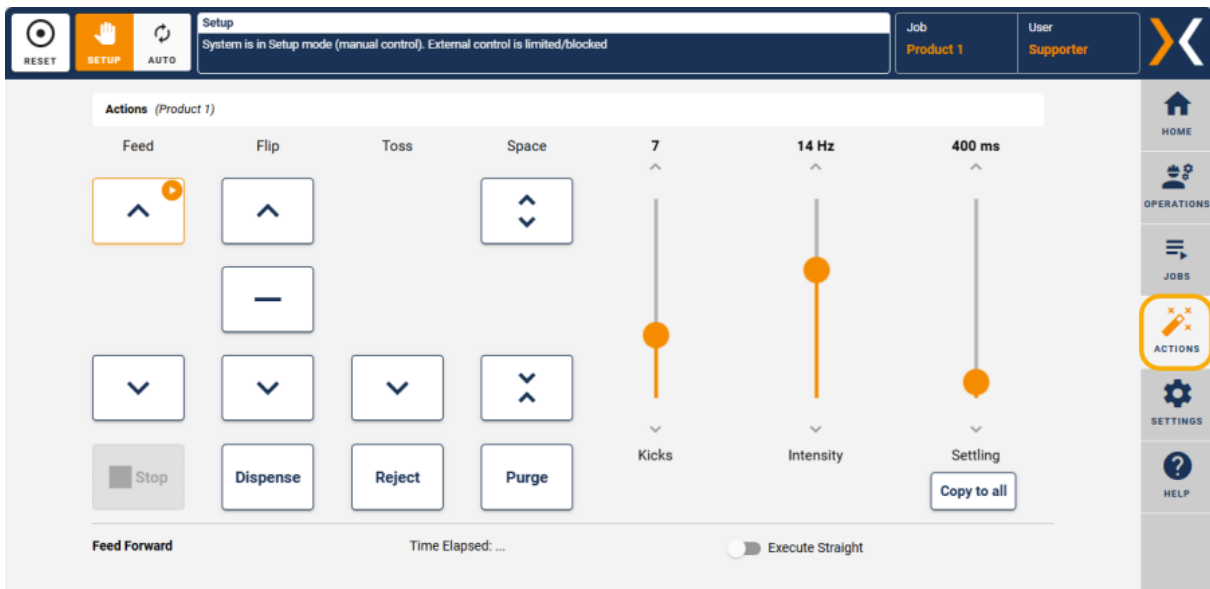

5 Additional information

You can find additional information about the installation in the assembly instructions document under the following link: [Assembly_Instructions_flexfeeder_XQ-Series.pdf](#)